

FURUNO

OWNER'S MANUAL

DFAX

(DUAL FUNCTION FACSIMILE RECEIVER)

MODEL FAX-208/A/N



FURUNO ELECTRIC CO., LTD.
NISHINOMIYA, JAPAN

©FURUNO ELECTRIC CO., LTD.

9-52, Ashihara-cho,
Nishinomiya, Japan 662

Telephone: 0798-65-2111
Telefax: 0798-65-4200

All rights reserved Printed in Japan

(TENI) PUB. No. OME-62430
FAX-208/A/N

-Your Local Agent/Dealer

FIRST EDITION : OCT 1986
T : JUL. 8, 1994

* 0 0 0 8 0 6 8 3 1 0 0 *

A WORD TO DFAX OWNERS

Congratulations on your choice of the FURUNO dual function facsimile receiver DFAX! We are confident that you will enjoy many years of operation with this fine piece of equipment.

For over 30 years Furuno Electric Company has enjoyed an enviable reputation for quality and reliability throughout the world. This dedication to excellence is furthered by our extensive global network of agents and dealers.

The DFAX (FAX-208 series) is just one of the many Furuno developments in the field of marine radio equipments.

Furuno is known as the first manufacturer of a single stylus all station-programmed facsimile receiver models FAX-108/143II. Your DFAX is loaded with various features; quiet thermal recording, fully-automatic operation, Navtex reception capability, affordable price range, etc. (Imagine, four microprocessors are working in the small cabinet!)

This unit is designed and constructed to ensure the user of many years of trouble-free operation. To obtain full performance from the equipment, however, you should carefully read and follow the recommended procedures for installation, operation and maintenance. No machine can perform its utmost ability unless it is installed and maintained properly.

Thank you for considering and purchasing Furuno equipment.

This manual is edited for the following three models;

Model	Function
FAX-208	Fax only (Navtex unavailable)
FAX-208A	Fax only (Navtex option)
FAX-208N	Fax plus Navtex

For identification, the operations and display messages corresponding to Navtex are denoted by "Navtex version only."

Any FAX-208A owner, who needs Navtex reception may consult his dealer or agent for incorporation of NAV RCV board.

TABLE OF CONTENTS

FEATURES	3
INSTALLATION	4 thru 8
General Mounting Considerations	4
Recorder Unit Installation	4
Antenna Installation	5
Cable Connections	6
Preset for Preamp Unit	8
OPERATIONAL OVERVIEW	9 thru 30
CONTROLS AND TOUCHPAD	9 thru 12
MANUAL RECORDING	13 thru 19
Power on/off	13
Adjustment of LCD Contrast and Dimmer	14
Selection of Facsimile Station and Frequency	14
Tuning	16
Setting the Internal Clock	16
Setting the Monitor Volume	16
Setting the SPD/IOC	16
Phase Matching	18
Signal Synchronization	19
Stopping Picture Recording	19
Sleep Mode	19
TIMER RECORDING	20 thru 23
Entry of Program Time	20
Revision of Program Time	22
Erasing Programmed Schedule	22
Printing Scheduled Program	23
UPDATING PREPROGRAMMED STATION/FREQUENCY	24 thru 25
Changing Programmed Data to a New Frequency	24
Adding a New Frequency	24
Recalling/Printing Frequency Data	25
SELECTION OF NAVTEX STATION AND MESSAGE	26 thru 28
Selection of Station and Message	26
Recall/Print of NAVTEX Station and Message	28
Monitoring the NAVTEX Signal	28
REPLACEMENT OF RECORDING PAPER	29
RECEPTION BY EXTERNAL RECEIVER	30
MAINTENANCE	31 thru 32
General	31
Fuse Replacement	31
Cleaning	32

TROUBLESHOOTING	33 thru 36
Operator Troubleshooting	33
Self-Test	35
EXPLODED VIEW AND PARTS LIST	37 thru 39
SCHEMATIC DIAGRAM	40 thru 41
SPECIFICATIONS	42 thru 45
APPENDIX A. PRINCIPLE OF FACSIMILE AND NAVTEX SYSTEMS	
How Facsimile System Works	APA-1
How NAVTEX Works	APA-3
APPENDIX B. EXTERNAL CONNECTIONS AND INTERNAL PRESETS	
External Input/Output	APB-1
How to Change Internal Settings	APB-4
APPENDIX C.	
Facsimile Station Map	APC-1
Facsimile Station List	APC-2
Facsimile Station List (Alphabetical Order)	APC-3
Private Channel List	APC-4
Schedule List for Timer Recording	APC-5
NAVTEX Station Map	APC-7
NAVTEX Station List	APC-8
APPENDIX D. IMPROVEMENT OF RECEIVER S/N RATIO	
(Remedy for RFI)	APD-1
APPENDIX E. IMPROVEMENT OF NAVTEX RECEIVING	
SIGNAL SENSITIVITY	APE-1

FEATURES

The FAX-208 series Facsimile Receiver has a wide variety of functions, all contained in a rugged metal-shilded plastic case that is compact and noise-free to fit almost any class of boat.

All keys respond immediately to the operator's command and each time a control touchpad is pressed an audible "beep" sounds to confirm that the command has been accepted by the unit.

Some of its prominent features are as follows.

- Parallel thermal head recording enables very quiet operation. Odors, fumes, carbon dust, electric noise, etc. are eliminated.
- Thermal paper provides a clear-cut, high-quality picture in four tones, white, light gray, dark gray and black. Cloud analysis picture in the FM mode is presented clearly.
- Programmed with all existing facsimile stations and frequencies, which may be updated by the user. 10 private frequency spaces are reserved additionally for the user.
- Fully automatic reception by the built-in on/off/sleep schedule timer, auto speed/IOC selection, auto phase alignment and intelligent optimum frequency selection facility.
- Menu-driven/dialogue guided operation enables sophisticated function with simple key sequences - the highest user-friendliness.
- Battery back-up for real-time clock, schedule, channel/frequencies and all user presets.
- Various self-tests available for easy service and maintenance.
- Simultaneous reception of facsimile pictures and Navtex messages.
- Optional preamp unit available for limited antenna site, providing stable signal on LF and HF bands with minimum onboard noise.
- Universal power supply from 10V to 40Vdc, drawing only 27W maximum.

INSTALLATION

GENERAL MOUNTING CONSIDERATIONS

This equipment can perform its intended functions only if it is installed properly. Prior to installation, the following precautions should be kept in mind.

Water spray

The recorder unit is designed and constructed to be able to withstand the humidity and corrosive atmosphere common in the small boats, but it is not designed to be used outside, directly exposed to the environment! Salt water spray will most assuredly cause damage to the sensitive components inside.

FURUNO will assure no responsibility for the damage caused by exposure to water spray.

Mechanical shock and vibration

The recorder itself is constructed to withstand minor shocks and engine vibrations, but excessive and continued shock can shorten the life of the precision printer mechanism. Shock may also degrade the print quality due to uneven contact between the printer head and the recording paper.

Heat accumulation

The DFAX consumes very little power, so there is no need for forced air ventilation. However, it is recommended to provide at least some space around the recorder unit to allow circulation of cooling air.

Even though the LCD (Liquid Crystal Display) is quite legible even in direct sunlight, it is recommended to keep the recorder unit out of direct sunlight or at least shaded because of heat that can build up inside the cabinet. Excessive heat can darken the thermal recording paper.

Onboard noise

The DFAX contains a very sensitive receiver. To avoid mutual interference with other radio or navigational equipment, do not install the recorder near an SSB/VHF/CB radiotelephone, direction finder or Loran receiver.

RECORDER UNIT INSTALLATION

The recorder can be mounted on either a bulkhead or table-top. Make sure the selected location is strong enough to support the unit against possible vibration and shock. If necessary, appropriate reinforcement measures should be made on the mounting area.

During unattended operation of the equipment, a long recorded paper may hang down from the recorder. To prevent the paper from running skew or being jammed on the way, level the recorder horizontally and keep the paper path clear so that the paper can run down smoothly. Also remember to leave some space below the paper container so that the container cover can flip down.

1. Loosen the two large screws (M6x40) in the paper container and detach the recorder unit from the mounting cradle.
2. Drill four pilot holes for the mounting cradle.
3. Fix the mounting cradle using the screws supplied ($\phi 5 \times 20$).
4. Mount the recorder unit onto the cradle and tighten the two screws mentioned above.

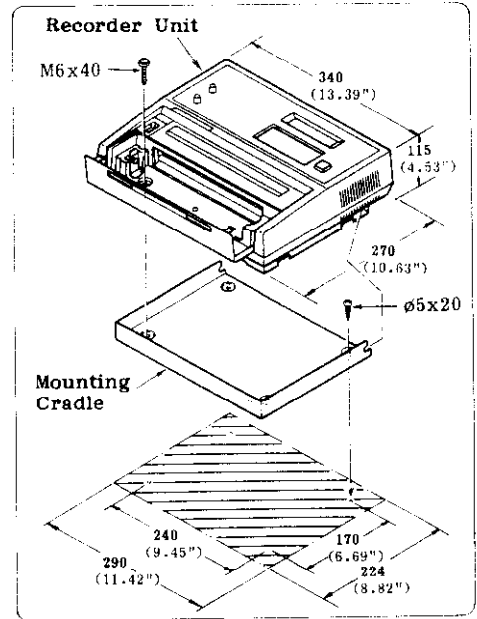

ANTENNA INSTALLATION

Performance of the DFAX receiver, especially in weak signal areas, is directly related to the antenna installation. In general, the antenna should be installed as high as possible on the boat, free from the influence of nearby antennas, rigging and masts.

The antenna commonly used for the facsimile receiver is a long-wire or whip of 6 meters or longer. In order to receive LF facsimile or Navtex signals in every situation, however, the total antenna length should be at least 15 meters.

To allow antenna installation on smaller boats where the long-wire antenna can not be stretched, the DFAX receiver is designed to be connected to an active antenna (preamp unit with 2.6m whip antenna) as well as a conventional long-wire antenna.

Passive antenna

If your boat is large enough, install a long-wire or whip antenna with slant wire of 15 meters or longer in total length. If a long antenna already exists for an all-wave receiver, it may be a good idea to share the antenna by using an antenna switch.

Do not share the antenna with the transmitter.

To minimize noise pick-up from onboard electronic equipment, a 50 ohm coaxial cable (RG-8/U, RG-5/U, etc.) should be used for indoor wiring. (Connect the center conductor to the antenna wire and insulate the outer conductor by using vinyl tape.)

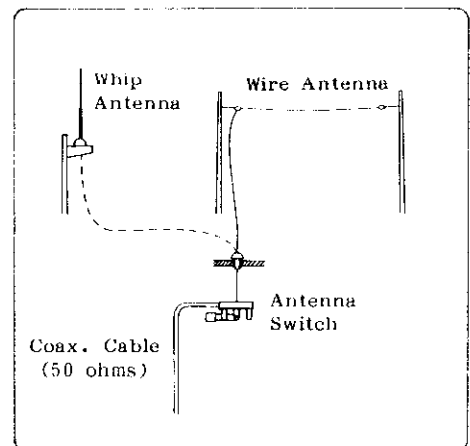

Active antenna (Preamp Unit; option)

If your boat is small and you can not provide space for such a long antenna, it is recommended to install the optional Preamp Unit and 2.6m Whip Antenna.

The body of the Preamp Unit can be mounted in two ways;

1. The bottom of the Preamp Unit is designed to accept a threaded extension mast of 1 inch diameter. The pitch of the thread should be 14 threads per inch. To prevent undue flexing of the mast in heavy winds, the mast should not be longer than 5 feet (1.5m).
2. The side of the Preamp Unit has a molded channel so that it may be mounted directly to a stub mast with two stainless steel hose clamps. Hose clamps must be arranged locally.

Screw the 2.6m Whip antenna tightly onto the Preamp Unit and waterproof the junction and other exposed metallic parts with sealing compound (silicone rubber, putty, etc).

Instead of using the 2.6m Whip antenna, a antenna wire of 2 to 3 meter long may be connected as shown right.

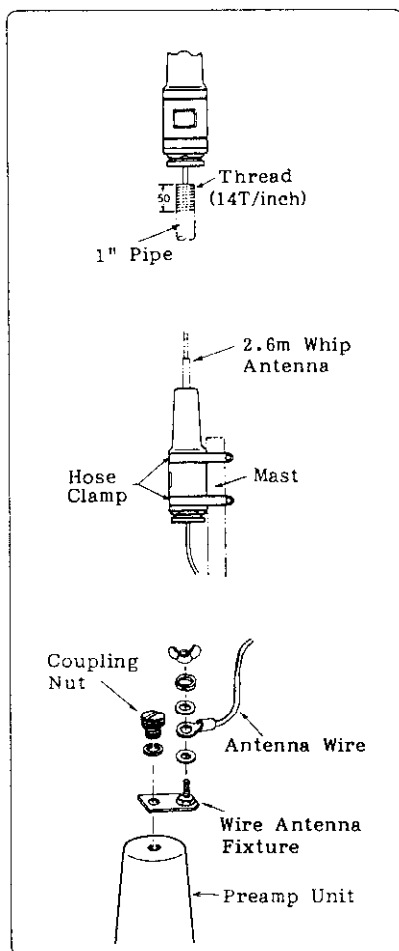

NOTE1: If the preamp unit (FAX-5) is installed, the preset switch (S1) inside the recorder unit must be set to "ACTIVE" side to supply 9Vdc to the preamp unit. Refer to page 8.

- 2: If receiver sensitivity is insufficient on preamp unit-equipped sets produced in February 1990 and after, ground the preamp unit referring to page APD-1.
- 3: If navtex signal can not be received clearly, install an additional navtex whip antenna with the preamp unit (NX-5), referring to page APE-1.

CABLE CONNECTIONS

Three cables must be connected to the DFAX receiver; power, antenna and ground.

The power and antenna cables are to be connected to their respective connectors at the rear of the recorder, and the grounding wire directly to the rear panel terminal. General connecting instruction is illustrated on the next page.

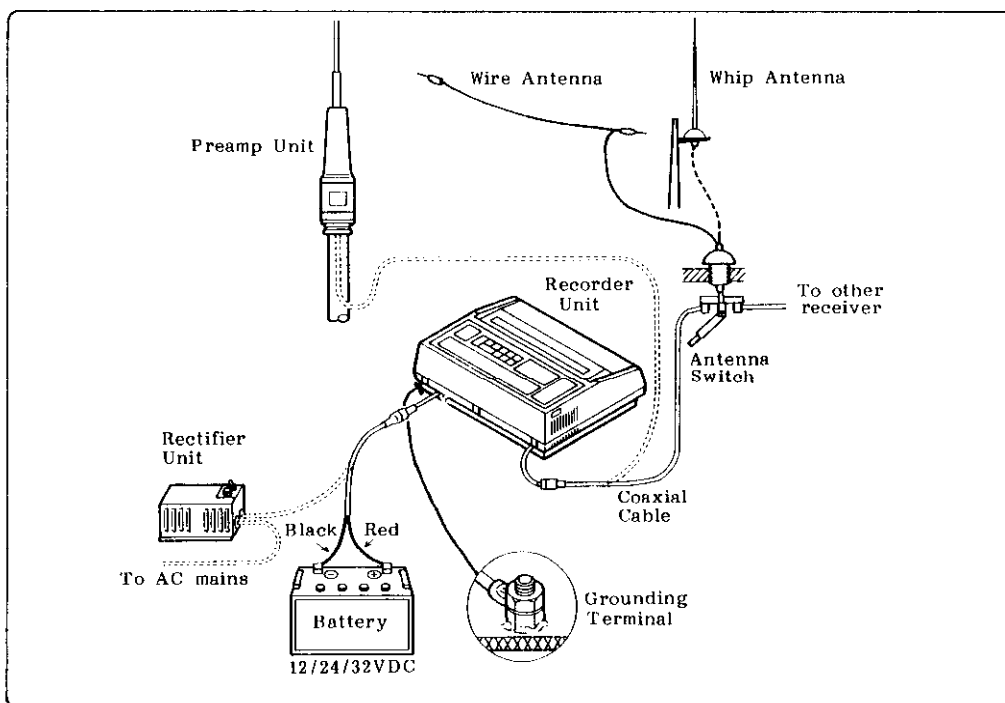

Power cable

The DFAX receiver is designed to operate normally at any voltage between 10 and 40Vdc, and thus it can be connected directly to 12V, 24V or 32V power system without any presetting inside the recorder.

For power connection, a 5m cable with snap-in fuse holders is provided. Connect its end leads to a distribution box, breaker panel or battery; the red lead to positive (+) terminal and the black lead to negative (-) terminal. The cable should be layed so that the fuse holders can be accessed easily.

— CAUTION —

To protect the equipment from transient voltage change and accidental reversal of the polarity of the power supply, fuses are provided in the power cable lead. Should the fuse blow, first suspect wrong polarity or shortcircuit. Locate and remove the cause on replacement of the fuse.

If it is necessary to extend the power line, use an appropriate size cable, taking into account of the supply voltage and extension length (thicker wire for lower supply voltage and longer extension distance). A 2mm square cable (US gauge 14, British gauge 16) will be sufficient for a 10m extension in the 12V system. Do not make the connection by twist wrapping but by soldering.

Antenna cable

If the Preamp Unit is installed, a coaxial plug is already connected at the end of 15m feeder. Connect the plug firmly to the female connector at the rear of the recorder.

If a wire and/or whip antenna is installed, run a 50 ohm coaxial cable between the antenna base (lead-in) and the recorder unit, and fabricate the cable end as shown below. Depending on the cable size, use an appropriate reducer, provided as standard supply. If you do not know how to solder, leave this job to a qualified technician, since most radio troubles are caused by improper antenna connections.

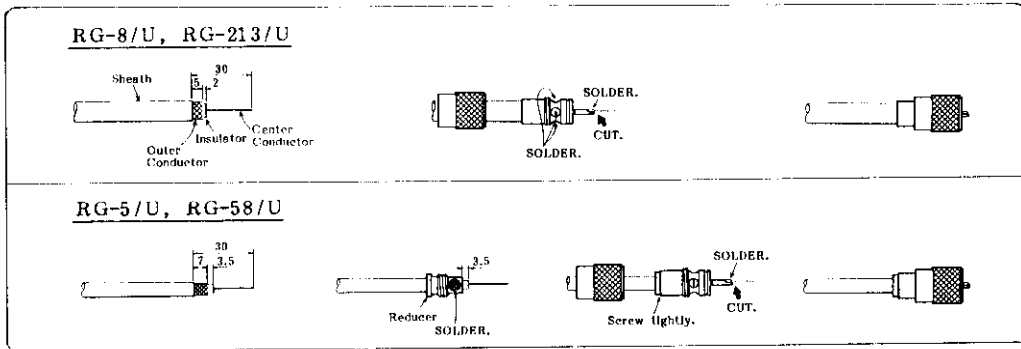

Grounding wire

In order to minimize noise pick-up from onboard equipment, it is important to ground the recorder unit to the boat's grounding bus.

Fasten the grounding wire (2m supplied) to the grounding terminal at the rear panel of the recorder, and connect the other end to the nearest efficient grounding spot on the boat. It is best to find a good grounding spot while receiving a signal.

PRESET FOR PREAMP UNIT

The Preamp Unit should be supplied with 9Vdc through the coaxial cable. When the Preamp is installed, set the switch inside the recorder as described below.

1. Detach the recorder unit from the mounting cradle. Refer to page 5.
2. Find the miniature slide switch S1 on the TB board (behind the rear panel), and set it to "ACTIVE."

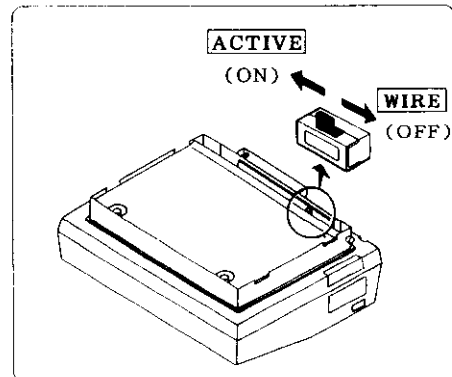

CAUTION

Don't make a shortcircuit between the center and outer conductors of the antenna connector.

Make sure the slide switch is set to "WIRE" when a conventional long-wire and/or whip antenna is used. Otherwise the recorder may be damaged due to an antenna shortcircuit.

OPERATIONAL OVERVIEW

The DFAX is a rather simple unit to operate, although at first glance it may be a little intimidating to someone who has never used a facsimile receiver. However once you get to know what the various abbreviations mean, the simplicity and the logic behind the panel layout will become more apparent.

The front panel is divided roughly into two blocks; controls and LCD display composed of 16 characters on the upper side, and the printer on the lower side. The keyboard, delineated by different color schemes, is located just below the LCD display. Each time a touchpad is pressed an audible beep is generated to signal the operator that the unit has received his command.

CONTROLS AND TOUCHPADS

ARROW KEYS

You may notice that there are no numeric keys on the panel, unlike other equipment which employ numeric keys to enter data. It means that entry of the numeric data or selection of the operating mode is performed by scrolling the number or message displayed on the LCD window. The vertical arrow keys [▲] and [▼] are used to scroll the menu upward or downward, respectively. On the contrary the horizontal arrow keys [◀] and [▶] are for moving the cursor for data entry (or recall) leftward or rightward. In some modes, however, these keys are also used to scroll the display sideways. Pressing the [▶] key when the cursor is located at the right-hand edge of the LCD display will scroll the window rightward. Similarly when the cursor is at the far left end, the [◀] key will scroll the window leftward. The figure below shows an example of sideways scrolling in the program timer mode.

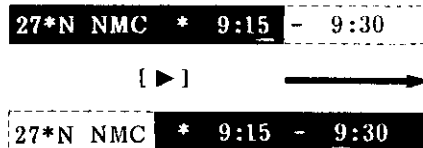

FUNCTION KEYS

The [MODE] and the [RCL/PRG] keys deal with several operating modes. The [MODE] key is used to turn on/off the printer in the manual recording mode, or to activate the timer/sleep modes. The [RCL/PRG] key stands for RECALL/PROGRAM, and is used to display or update the current time data, frequency data, timer program, NAVTEX station and message data (the NAVTEX version only), etc. The first pressing of the [RCL/PRG] key selects the Recall function, then pressing the same key again will call up the Program function. When you press the [RCL/PRG] key once, the function "Time" is selected first since it is a default setting. Other functions may be

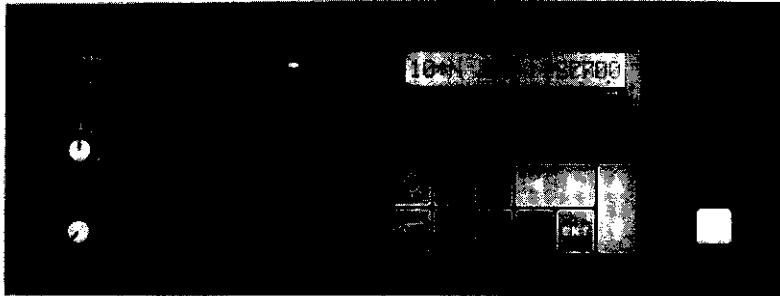

FURUNO DFAX

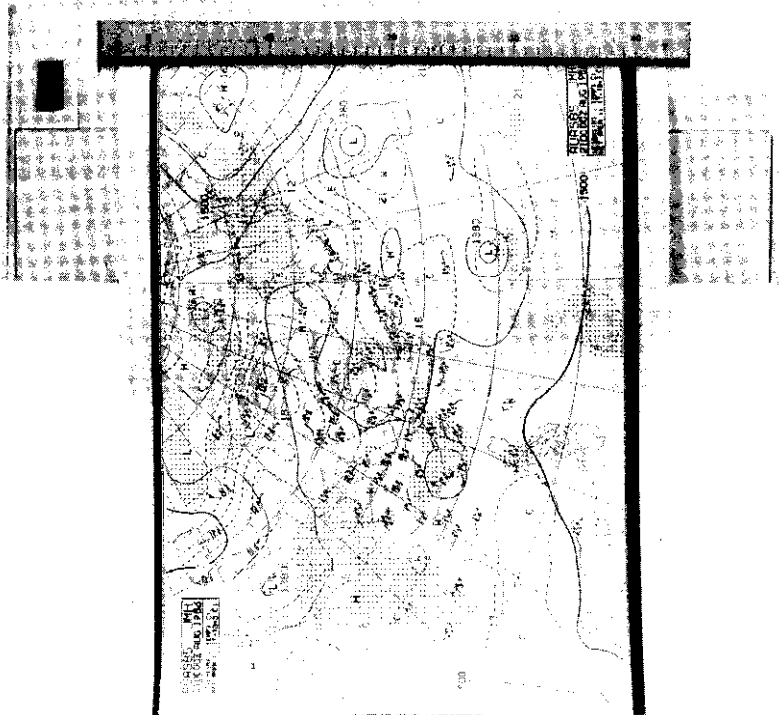

FURUNO DFAX (FAX-208A/N), Front Panel

selected by scrolling the display with the [▲] or [▼] key as shown below. To activate the function selected, press the [ENT] key. If you accidentally type in the [MODE] or [RCL/PRG] key, select the escape message of each menu and hit the [ENT] key to retrieve the unit to the normal operation.

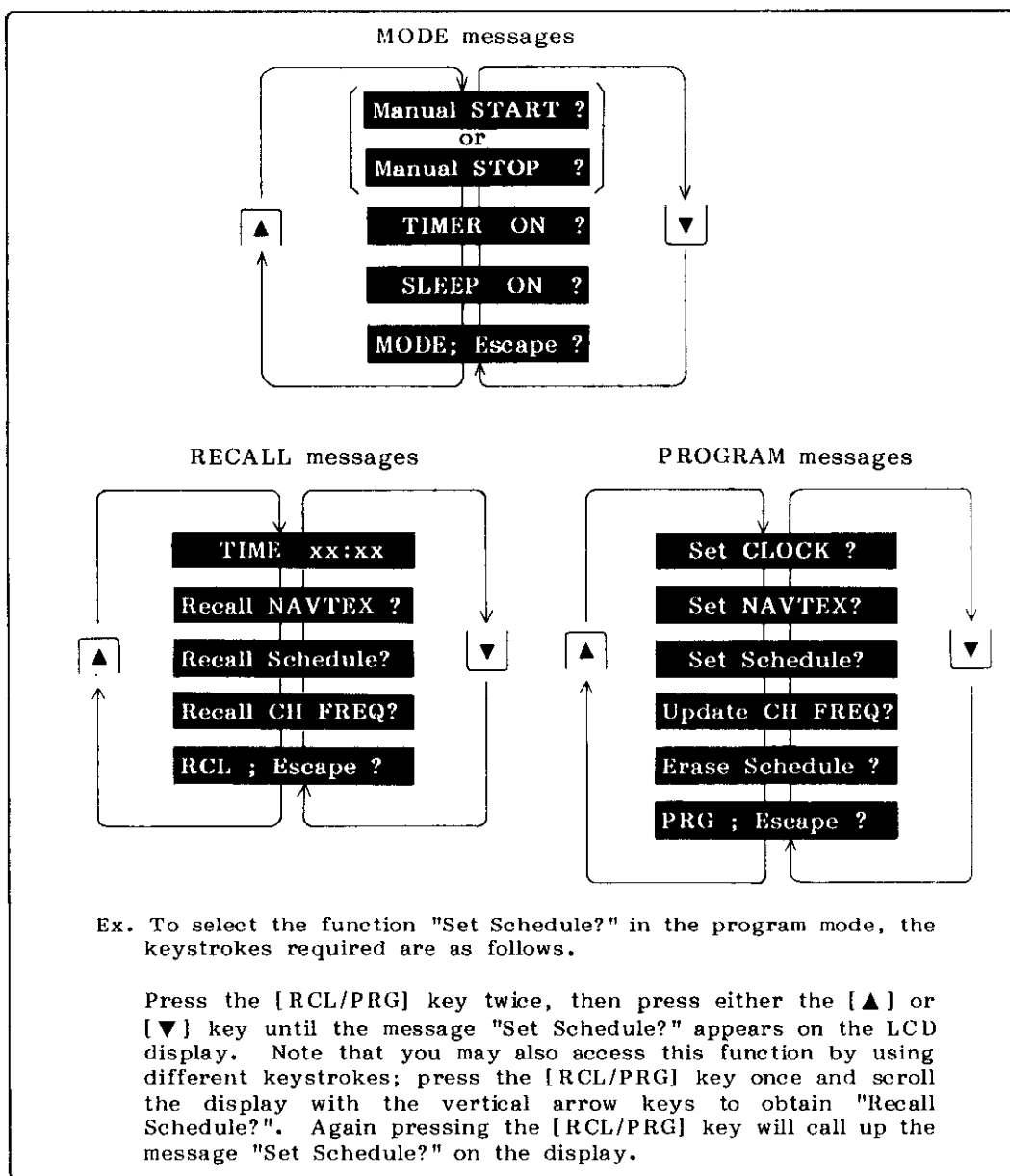





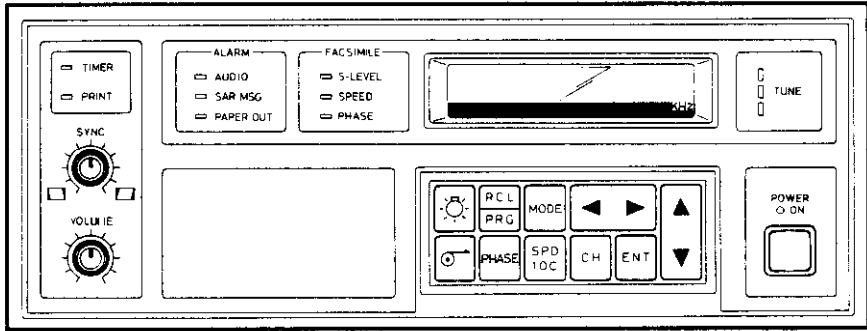









OTHER KEYS

The symbols or abbreviations printed on the [⊖], [⊙], [PHASE], [SPD/IOC] and [CH] keys directly represent their functions. For instance, the [⊖] key is used to feed the paper and the [⊙] key is for varying the backlighting of the LCD display. The name and function of each control and touchpad (including LED) are recapitulated on page 12.



CONTROLS AND TOUCHPADS

-  Turns on/off the unit.
-  Equalizes picture synchronization to align with the paper feed direction.
-  Adjusts audio level of the monitor speaker.
-  Used to vary the level of backlighting of the LCD display and intensity of LED.
-  Adjusts the contrast of the LCD display.
-  Used to feed paper.
-  Adjusts picture phase.
-  Selects speed and IOC numbers.
-  Used to call up station and frequency data.
-  Used to enter data or activate a function.
-  Used to recall data stored in the memory, or used to program data.
-  Used to control the operation of printer.
-  Used to scroll a number or message upward or downward.
-  Used to move the cursor or data entry message sideways.

LEDS

- Tune** Three indicators run upward or downward when the programmed frequency differs from the actual receiving one.
- S-level** Lights when the signal is too weak to receive.
- Speed** Lights when the scanning speed is incorrectly set.
- Phase** Lights when the picture is out of phase.
- Audio** Lights when the alarm mode is activated.
- SAR MSG** Lights when receiving the search and rescue message of NAVTEX signal.
- Paper out** Lights when the recording paper runs out completely.
- Timer** Lights when the timer mode is operating.
- Print** Lights while the picture is being printed.

MANUAL RECORDING

As was described in the FEATURES section, the DFAX employs a unique timer which enables automatic recording of facsimile signals up to 16 programs according to a preset schedule. In this section, however, the basic operating procedure for manual recording is explained step by step to familiarize you with the controls and touchpads on the front panel. Details for the operating procedure of the Timer Recording are explained in the next section.

Before you do start operation, obtain a radio facsimile frequency list for your area. The Facsimile Station List attached to the appendix of this manual may be useful to quickly find out the call sign and frequency in your area, since it is arranged in alphabetical order according to country. Make sure that the recording paper is properly loaded, referring to page 29.

POWER ON/OFF

Power on/off of the unit is made using the POWER button located on the lower right of the front panel. Press the POWER button and you will see the time displayed on the window for several seconds. Then, the display will change to channel data: zone, station and channel numbers plus picture mode (refer to page 21 for details of the picture mode), followed by a call sign and frequency in this order. When a specific function is completed by the action of keystrokes, the unit returns to the normal display, indicating the channel data previously selected.

The very first time you turn on your unit, don't worry about the stray data displayed on the window (the time may be inconsistent with the local time in your area and the call sign may be unknown to you), since these were set at the factory.

To turn off the power press the POWER button again.



FURUNO <DFAX>

TIME 12:34

100N JMH 32665

↑ Freq.
↑ Call sign
↑ Zone, Station, Channel numbers and Picture mode

[Normal Display]

Initialization of the unit (Cold Start)

The DFAX is designed to retain in memory all information entered by the user (such as time, programmed schedules, etc.) whether it is turned on or off. An internal "Keep-alive" battery, of which the estimated life is five years, performs this function. However, data in the memory may become jumbled due to a dead battery or accidental loosening of the plugs connecting the pc boards. In either case, you have to clear the memory to ensure that no stray data has been stored there. Again make sure that all data that you had previously entered will be lost after this operation. Upon clearing the memory, the unit is reset to the following default value.

1. Time data : 0:00
2. Program schedule : Cleared
3. Frequency data updated by the user : Cleared
4. Zone, station and channel data in normal mode: "100N JMH 32665"
5. NAVTEX station and message : All registered in capital letter
6. Audio alarm : ON

Note: Items 5 and 6 are applicable only for the NAVTEX version.

In order to initialize the unit, turn off the unit first, then hold down the [CH] key while pressing the POWER button. The message "Cold Start?" will appear on the display. Hit the [ENT] key and the message will change to "TIME 0:00," notifying the operator that the unit is now defaulted. Note that the channel and frequency data preprogrammed at the factory cannot be erased, since these are exclusively stored in the ROM, of which the contents are not retained by the battery.

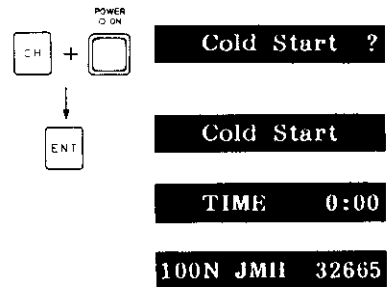

ADJUSTMENT OF LCD CONTRAST AND DIMMER

Because of its polarized characteristics, the intensity of the LCD (Liquid Crystal Display) varies with not only the viewing angle of the operator, but also the environmental temperature. The CONTRAST control located at the left-side panel of the unit is provided to equalize the degree of the polarization. Be aware that too clockwise a setting may result in blackening of the entire LCD.



The [☉] key is used to vary the level of backlighting of the LCD display and the brightness of the LED indicators for nighttime operation, in three steps of bright, dim and off. Each time the [☉] is depressed, the level will change in the above sequence. Note that the alarm LEDs will not light up at the "off" setting.

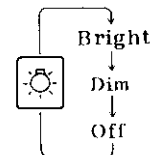

SELECTION OF FACSIMILE STATION AND FREQUENCY

The facsimile station will usually transmit signals at several different frequencies on the HF band (a few stations also transmit on the LF band) so that the optimum frequency for a quality recording may be selected at the receiving end. In choosing a receiving frequency, the general rule of thumb is to select the highest useable frequency band for the initial attempt, then move to a low band if the picture is not reproduced satisfactorily.

In practice, since receiving conditions on the HF bands are greatly affected by natural phenomena as well as the distance between the transmitting station and receiver, selection of the optimum frequency is required whenever you want to receive the facsimile signal.

To overcome this inconvenience, the DFAX employs a scan function which automatically searches the frequencies assigned to a station and locks onto the frequency which has the highest signal strength.

- Note 1. If the signal level of more than two channels are the same, the higher frequency takes priority over others.
2. When an LF channel having a certain level is detected, the receiver exclusively locks onto the LF channel irrespective of the signal level of other channel.
3. The receiver recommences scanning if the signal level of the locked channel drops below a preset threshold for more than two minutes.

Of course, a commonly-used monitor function for judging signal strength with a built-in speaker is also available. The sequence of keystrokes to select a desired station would be:

Pressing the [CH] key, the station and frequency data appear on the display. The character where the data entry cursor is placed will be flashing to indicate that the unit is ready to accept the operator's command.



100N JMH 36225

Arrangement of station and frequency data

ex. 100N JMH 36225

- Call sign
- Frequency (unit: 100Hz)
- Picture mode: N(normal/USB) or R(reverse/LSB)
- Channel number (Note 1)
- Station number (Note 2)
- Zone number

Note 1. To activate the scan function, select the asterisk mark "*" instead of a number.

Note 2. The station number is fixed to zero when selecting the zone number to zero (private channel).

Select the zone number of the desired station by scrolling the numbers on the window with the [▲] or [▼] key. Hit the [▶] key to move the cursor to the next data column and set the station number. In the same manner, get into the scan mode by selecting the asterisk "*" on the column of the channel number. If a specific frequency is always received stably in your area, enter the channel number instead of "*".

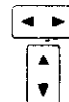

100N JMH

27* NMC

On completion of the data entry, press the [ENT] key and the unit starts scanning the frequencies allocated. The display will show the message "...* ... SCAN " while scanning, then will indicate the frequency on which the receiver has locked onto.



27* NMC SCAN

27*N NMC 127300

TUNING

There are rare occurrences, where the actual receiving frequency slightly deviates from the nominal transmitting frequency. The TUNE indicator, composed of three lamps will "flow" upward when the receiving frequency is lower than the preprogrammed frequency data. Press and hold the [▲] key until the indicator stops flowing and only the center lamps lights stably. On the contrary, press the [▼] key if the indicator flows downward.

- Note 1. The TUNING is inoperative when selecting the scan mode.
2. The indicator will always flow for a signal in LF band or for a picture of which the most part is occupied by the black signal, irrespective of frequency deviation.

SETTING THE INTERNAL CLOCK

It is necessary to set the built-in clock to the local time in your area or GMT (Greenwich Mean Time) to properly operate the sleep mode and timer recording. The meaning of the sleep mode and timer recording are described later on.

Press the [RCL/PRG] key and the time is displayed on the window.



TIME 12:34

Again press [RCL/PRG], then [ENT]. You will see the message "Set CLOCK?" followed by "Set CLOCK xx:xx" on the display.



Set CLOCK ?



Set CLOCK 12:34

Set the time to the incoming time signal by using the arrow keys and press the [ENT] key at the exact moment the time signal is released for the start of a new minute/hour.

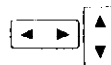

Set CLOCK 11:50

SETTING THE MONITOR VOLUME

The unit incorporates a speaker for monitoring the received signal. The MONITOR control located on the left-hand of the panel adjusts the audio output level from the speaker. Push in and release the control to bring it out.



SETTING THE SPD/IOC

Next, you may have to set the correct SPD/IOC number depending on the facsimile station. SPD and IOC stands for scanning speed and index of corporation, respectively. These are a kind of synchro code to reproduce an exact copy of the picture transmitted from the facsimile station, and are listed on the Facsimile Schedule Book. If the SPD is incorrectly set, a part of the picture will be overlapped or a multiple picture will be recorded. You will also be notified of a wrong SPD setting by the lighting of the SPD LED.

Similarly, the picture is foreshortened or expanded to the paper feed direction if the IOC is set incorrectly. Four SPDs and two IOCs are available to meet the requirements of WMO and ITU: 60, 90, 120, and 240 for SPD, and 288 and 576 for IOC. Find the appropriate SPD and IOC of the desired station from the Facsimile Schedule Book and set them following the procedure.

Incorrect setting of the SPD/IOC numbers

Two pictures

Wrong selection of the SPEED number ("60" is selected instead of "120".)

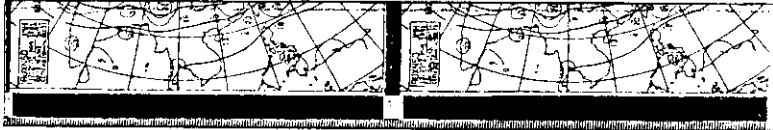

Overlapped recording

Wrong selection of the SPEED number ("120" is selected instead of "60".)



Expanded or foreshortened recording

Wrong selection of the IOC number. When "288 (576)" is selected for transmission with the IOC of "576 (288)", the recording will be extended (foreshortened) in the paper feeding direction.



Hit the [MODE] key, and the message "Manual START?" will come up on the display. With the [ENT] key pressed, the message will change to "SPD/IOC xxx/xxx".

MODE

Manual START ?

ENT

SPD/IOC; 60/576

Scroll the number with the [▲] or [▼] key until the proper SPD number appears on the display. Hit the [▶] key to shift the cursor to the data column for IOC and select the proper IOC in the same manner as SPD selection.

On completion of SPD/IOC settings, press the [ENT] key. Now the printer plots the recording data followed by a picture as shown on the next page.

27*N NMC 171512

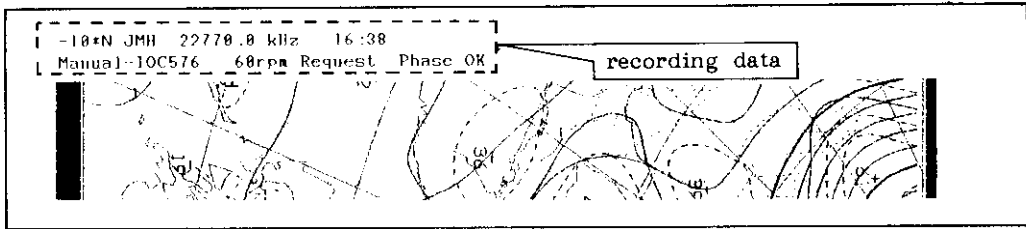

If you cannot find the correct SPD and IOC for the desired station, try recording at any setting of SPD and IOC. After several inches of printed paper comes out from the unit, check whether the picture is printed normally or not. If not, hit the [SPD/IOC] key, change the value with the arrow keys, and press the [ENT] key.

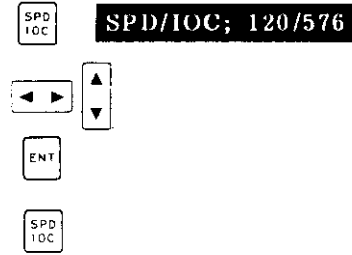

To escape from this mode, press the [SPD/IOC] key. Note that the selection of SPD/IOC by using the [SPD/IOC] key is effective only while the printer is operative.

PHASE MATCHING

When the printer starts recording after the phase signal (see page APA-2) was transmitted, or when the received signal is too weak in failing to detect the phase signal, the recording may be split into two parts by a thick white (or black) gap called a dead sector as illustrated. The [PHASE] key is provided to compensate for the phase mis-matching, shifting the dead sector to the left edge of the recording paper. When this may occur, the PHASE LED will light up and the message "Phase NG" will be printed out as the recording data.

Note: When receiving the signal having a black dead sector, the mis-matching occurs infrequently since the black dead sector is also used to align the picture phase.

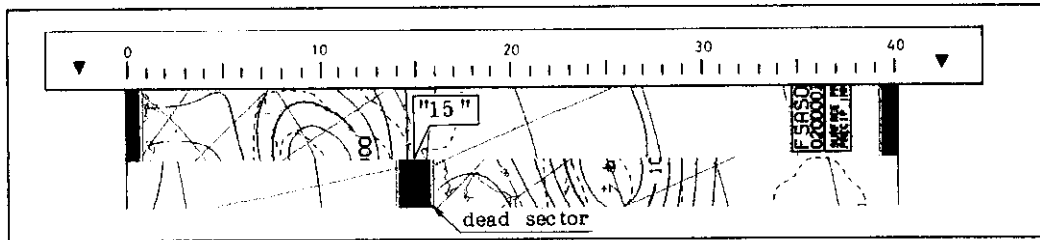

Press the [PHASE] key and the message "SET PHASE 00" appears on the display.



Read the scale at the center of the dead sector and enter the value in the data column by using the [▲] or [▼] key. The value to be corrected will range between 0 and 40.



Hit the [ENT] key and the dead sector is shifted to the left edge of the recording paper. Note that the [PHASE] key is also effective only while the printer is operative.



SIGNAL SYNCHRONIZATION

The SYNC control fine-tunes phase matching. If the dead sector is plotted askew even when the PHASE is properly selected, turn the SYNC control to correct it as illustrated.

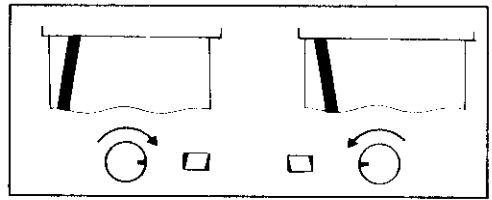

STOPPING PICTURE RECORDING

When the picture recording is desired to stop on the way or after completing the reception from the station in which "remote stop signal" (see page 21 and APA-2) is not transmitted, take the following procedure.

Press the [MODE] key and the display will indicate the message "MANUAL STOP?" for verification. Hit the [ENT] key. Now the printer stops recording and the unit is restored to the normal mode, indicating the channel data.

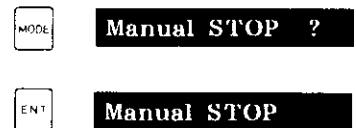

SLEEP MODE

As was described in the above section, the manual mode requires that you manually stop the printer after a picture is received, which can be quite a nuisance if you are preoccupied with other tasks. To free the operator from this inconvenience and to minimize recording paper consumption, an automatic stop of the recording is available.

There are two ways in which the "time to stop recording" may be selected; "timer sleep" and "remote sleep". In "timer sleep", the printer stops recording at the time designated by the operator, while "remote sleep" operates by detecting the "remote control signal". Note that once the printer stops operation, indicating only the message "OFF Facsimile", the unit is inoperative just as if it were turned off. To restore normal operation, press the [MODE] key. The key sequences to operate the sleep mode are as follows:

Press the [MODE] key, then scroll the menu with the vertical arrow keys to display the message "SLEEP ON?". Press [ENT] and the message will change to "OFF at _ : ". If the [ENT] key is pressed again while the data columns remain blank, the printer stops immediately and enters the sleep mode.

To activate the "timer sleep" function, enter the desired time into data columns **B** and **C**. The "remote sleep" function is activated by setting the asterisk "*" on data column **A** using the vertical arrow keys. After completing the setting, press [ENT] key to set the unit to sleep mode.

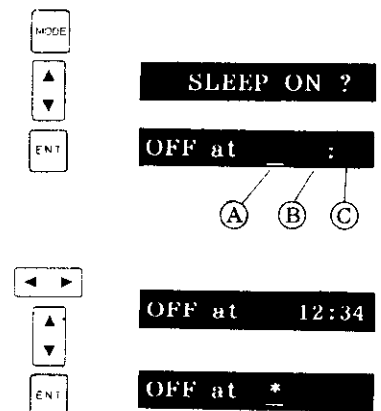

TIMER RECORDING

Most of the LF to HF facsimile broadcasts all over the world are regularly serviced according to a schedule issued by the meteorological observatory in each country. Therefore, if you wish to print a certain facsimile signal on a daily basis, the timer recording mode will virtually allow you "hands-off" automatic operation (self start and stop of the printing) once it has been preprogrammed.

ENTRY OF PROGRAM TIME

You may preset up to 16 programs for timer recording. Prepare the Facsimile Schedule Book including the time table for your area and record the broadcasting start and end time of the desired stations onto a note book for reference.

1. Press the [RCL/PRG] key twice, then scroll the menu with the [▲] or [▼] key until the message "SET Schedule?" appears on the display.

RCL PRG RCL PRG



Set Schedule?

2. Hit the [ENT] key and the message will change to the data entry display for the program timer, of which the data columns are arranged as shown below. In order to call up the data column for the program end time, scroll the display leftward by using the [▶] key.

FNT

000N PRV * 0:00

If the timer programs has been preset in full, the message "Schedule Full!" will appear instead of the data entry display and the unit reverts to the normal mode.

Schedule Full!

The data column is arranged as follows

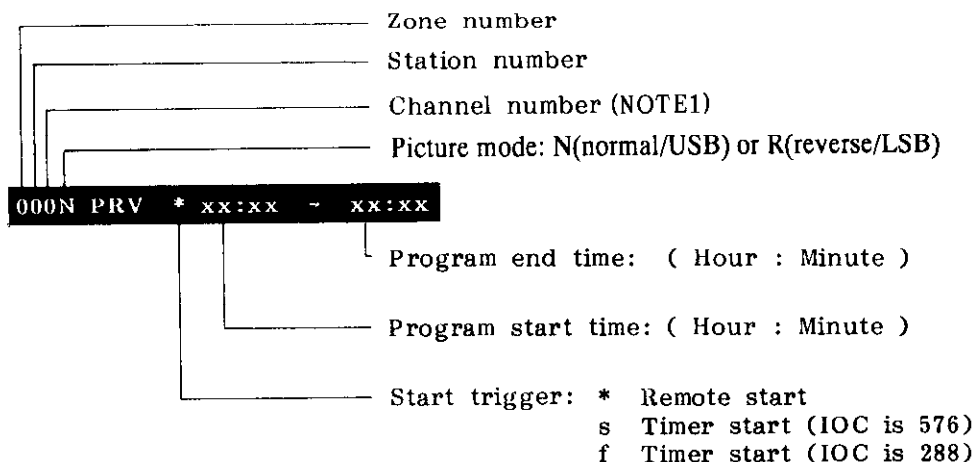

NOTE1: You may change to other channel numbers when receiving condition of the channel in use becomes bad due to signal attenuation and so on.

Picture mode: Some facsimile broadcast stations transmit a "reverse picture," white characters on a black background. The method by which each station broadcasts the picture has been programmed into the memory. However, if a newly established station transmits a reverse picture, you should designate the picture mode as "R" to print the picture in the normal manner. The "R" setting also allows reception of stations transmitting on LSB.

Start trigger:
 [Remote start] Two trigger modes are selectable; "remote start" or "timer start." In the remote start, the printer is in stand-by status at the program start time, then records the picture in response to the "remote control signal" (start and stop signals of a picture) transmitted from the station. The IOC number is also correctly chosen by the remote control signal.

[Timer start] In the "timer start mode," the unit searches for phase signal for three seconds when the programmed time arrives. If phase signal is not detected, the unit stops operation and waits for remote start signal.

Since, in practice, most of the facsimile stations transmit the "remote control signal" according to the WMO standard, it is recommended to select the "remote start mode" to ensure reception of the entire picture and to minimize paper consumption.

For example, suppose that you want to receive the facsimile signal transmitted from station NAM in Norfolk, Virginia, U.S.A. by the "remote start mode."

Zone: 5, Station: 3, Frequency: Scan mode, Start trigger: * ,
 Receiving Time: 13:20 to 13:45

3. Move the cursor to the bottom of the zone column with the [◀] key and scroll the number to obtain "5" by using [▲] or [▼] key. Enter the station, frequency, start trigger and program start time.



4. With the [▶] key pressed when the cursor is located at the far right side of the data column, the data entry display is scrolled leftward and the cursor jumps to the data column of the program end time. Enter "13:45".

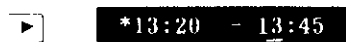

5. When data entry is completed, press the [ENT] key. The message "SET" will appear for about two seconds to notify the operator that the unit has accepted his command.



6. Repeat steps 1 through 6 to enter other scheduled programs.

7. To activate the timer function, hit the [MODE] key, scroll the message in order to display "TIMER ON" on the LCD window, then press the [ENT] key. Now the display will be changed to the programmed schedule most closest to the present time. If no schedule is programmed, the message "No Schedule !" will be displayed.

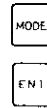

TIMER ON ?

No Schedule !

8. In timer mode, all keys except dimmer, paper feed and [MODE] keys become inoperative. To escape from timer mode, press [MODE] key. Display returns to normal.

Caution on programming timer

- When two programs overlap each other, the latter program becomes invalid. For instance, if the start/stop time of the program A and B are set to 2:00 → 2:30 and 2:15 → 2:40 respectively, the program B will not be recorded.
- When selecting the remote start mode, the program start time should be set at least one minute earlier than the actual broadcasting time in order to acquire the remote control signal without error.

REVISION OF PROGRAM TIME

If you want to partially change the programmed schedules, for instance, the broadcasting time of a specific station has been changed, perform the following keystrokes to quickly call up and update the time data.

Press the [RCL/PRG] key once, scroll the message in order to obtain "Recall Schedule?" with the [▲] or [▼] key, then hit [ENT].



Recall Schedule?

Of the preprogrammed schedules, the one of which the program start time is the earliest will appear on the window. Scroll the display with the vertical arrow keys until the schedule to be revised appears on the window; pressing the [▲] key calls up the schedule from an earlier time setting and the [▼] key, from a later time setting.

53* NAM * 2:10

52* WLO * 17:25

Press [RCL/PRG] again to get into the timer program mode. Update the schedule in the same manner as the "Entry of Program Time." See page 20.



52* WLO * 17:25

ERASING PROGRAMMED SCHEDULE

If necessary, the programmed schedule can be erased partially or totally by using the following keystrokes.

Partial erasure

Perform the same keystrokes as "Revision of program time" to get the program schedule.

Press and hold the [▶] key to scroll the display leftward until the program end time appears on the window.



52* WLO *17:25

*17:25 - 17:45

Change the program start time to the same time as the program end time (or vice versa) with the [▲] or [▼] keys, then press [ENT]. After displaying the message "Erase" for about two seconds, the unit reverts to the normal display.



*17:45 - 17:45



Erase

Complete Erasure

Press the [RCL/PRG] key twice, then scroll the message with the [▲] or [▼] key in order to display the message "Erase Schedule?".

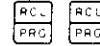

Erase Schedule ?



Hit the [ENT] key and the message will change to "Erase OK? (Y/N)", verifying your command to avoid inadvertently erasing the programmed schedule by accidentally pressing the [ENT] key. Place the cursor under the character "Y", then hit the [ENT] key. After indicating the message "ERASE" for about two seconds, the unit reverts to the normal display.



Erase OK ? (Y/N)



Erase

If the unit gets into this mode by mis-operation, move the cursor to the character "N" and press the [ENT] key. The display will show the message "Escape" and the unit will return to the normal display.



Erase OK ? (Y/N)



Escape

PRINTING SCHEDULED PROGRAM

The scheduled programs can be printed out for reference.

Turn off the unit first then hold the [RCL/PRG] key while pressing the POWER button. Scroll the menu by using the [▲] or [▼] key to display the message "Print Schedule?". With the [ENT] key pressed, the printer will plot the program as shown below.



Print Schedule ?

```

*** Schedule ***

27* NMC          *15:03 - 15:13
27* NMC          *17:18 - 17:30
26* CKN          *21:48 - 22:10
  
```

→ Start Trigger
(Remote Start)

UPDATING PREPROGRAMMED STATION/FREQUENCY

All frequency data for existing facsimile stations are preprogrammed in the built-in memory at the factory. However, if the transmitting frequency of a specific station is changed or a facsimile station is newly established, it is necessary to update the contents of the memory following the procedure shown below.

CHANGING PROGRAMMED DATA TO A NEW FREQUENCY

For example, assuming that the Kodiak, Alaska station will change the frequency in channel number 4 from 17192kHz to 17183kHz, perform the following keystrokes.

To call up the updating mode, press the [RCL/PRG] key twice and the message "Update CH FREQ?" will appear on the display.

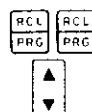

Update CH FREQ?

Hit the [ENT] key and the data entry display "000N PRV 799" appears on the window.



000N PRV 799

Place the cursor on the zone column by using the horizontal arrow key and select the number 2 with the [▲] key. Similarly, set the station and channel number to 5 and 4, respectively.



254N NOJ 17192

Move the cursor to the frequency column and select the numbers 1, 7, 1, 8 and 3 with the arrow keys.



254N NOJ 17183

After verifying that the proper frequency data is selected, press the [ENT] key to store it in the memory.



Set

100N JMH 32665

ADDING A NEW FREQUENCY

A new frequency may be added into the extra memory area (up to 14 channels) allocated in the zones tabulated on the next page. You may enter the frequency data into any channel of these zones. However, for convenience, it is recommended to select the zone in which you are fishing, sailing, etc. If you want to distinguish the data newly entered from the programmed one, zone "0" should be selected since it is exclusively allocated as a private channels. The operating procedure is the same as the above section "Changing programmed data to a new frequency".

Note: The call signs (PRV, AUX) assigned to these zones cannot be changed.

The frequency data updated by the user may be erased when initializing the unit as described on page 13.

Zone No.	Station ID	Call Sign	Channel No.
0	0	PRV	0 to 9
2	9	AUX	0
6	9	AUX	0
7	9	AUX	0
8	9	AUX	0

RECALLING/PRINTING FREQUENCY DATA

All frequency data stored in the memory (including the one entered by the user) can be recalled on the display or printed on the recording paper for reference.

Recalling

Hit [RCL/PRG] followed by [▲] or [▼] to obtain the message "Recall CH FREQ ?" on the display. Press the [ENT] key and the display will show the channel data previously selected.

RCL
PRG

▲
▼

ENT

Recall CH FREQ ?

By using the arrow keys, select the desired station and frequency number.

In order to escape from this mode and to return to the normal display, press the [ENT] key.

ENT

Printing

In order to print the frequency data turn off the unit first, then hold the [RCL/PRG] key while pressing the POWER button. Scroll the display with the vertical arrow keys to obtain the message "Print CH FREQ ?", then hit the [ENT] key. When the printing is completed, turn off the unit to escape from this mode.

RCL
PRG + POWER

▲
▼

ENT

Print CH FREQ ?

*** Channel Frequency ***						
		Zone No.0				
Station - 0	PRV	799	799	799	799	799
		Zone No.1				
Station - 0	JMH	36225	49020	73050	99700	135970 182200 227700
Station - 1	JMJ	33650	54050	94380	146925	181300
Station - 2	JJC	10160	96190	127455	160000	162700 238644

The channel frequency is shown in 100Hz.
ex. 182200: 18220.0kHz

SELECTION OF NAVTEX STATION AND MESSAGE

This chapter describes the operating procedure according to selection of the NAVTEX station and designation of the message to be received, and is applicable only for the NAVTEX version.

As stated in detail in the Appendix of this manual, the header code of all messages are prefixed by a four character group; the first character denotes the identity of the transmitting station, the second specifies the category of message and the next two give serial numbers between 00 and 99 in transmitting order. It should be noted that serial number 00 is exclusively assigned to an important emergency message. The list below shows the category of each message. As for the station list, refer to page APC-8.

- A. Coastal navigational warning
- B. Meteorological warning
- C. Ice report
- D. Search and Rescue Alert
- E. Meteorological forecast
- F. Pilot message
- G. Decca message
- H. Loran-C message
- I. Omega message
- J. Differential Omega message
- K. Other electronic Navaid system messages
- L. Navarea warnings
- M-Y. No category allocated
- Z. QRU (no message on hand)

Any category from the above list may be selected. However, all NAVTEX receivers are required to print out messages A,B and D, which are considered essential for warning of hazards or other information of concern to the oceangoing navigator. When the NAVTEX signal is received during reception of a facsimile reception signal, the NAVTEX message is stored in the memory and is printed when the facsimile is completed. Note that a message type D will be printed immediately even when the facsimile recording is in progress. If required, the FAX-208/A/N can sound an audio alarm when receiving a D type message, in addition to the lighting of the SAR MSG (Search And Rescue Message) annunciation LED. (See step 7 below)

SELECTION OF STATION AND MESSAGE

1. Press the [RCL/PRG] key twice, then scroll the menu by using the [▲] and [▼] keys in order to display the message "Set NAVTEX?".



Set NAVTEX?

2. Hit the [ENT] key, and the NAVTEX stations will be displayed with their identification letters A to H in alphabetical order. The remaining letters I to Z may be called up by scrolling the data column leftward with the [▶] key; place the data select cursor to the far right side of the data column by using [▶], then further pressing the same key will scroll a series of letters from right to left.



Station; ABCDEFGHIH



Station; ABCDEFGHI

ion; ABCDEFGHIJKL

3. Registration of the NAVTEX station is made by setting the identification character in capital letters. Pressing the [▲] or [▼] key alternately selects a capital or small letter where the cursor is placed.

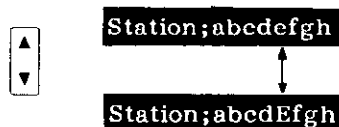

4. For example, assume that you want to select Reykjavik, Iceland, of which the identification letter is R. Press and hold the [▶] key until the data cursor is placed under the letter "r", then hit either the [▲] or [▼] key to change "r" to "R", followed by [ENT]. Now the registration of the NAVTEX station is completed and the message "SET" will appear for a while on the LCD display.

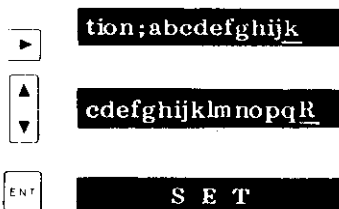

5. Next, the NAVTEX message will come up on the window. In the same manner as the station selection, set the code of the message desired in capital letters. Note that, as mentioned before, watch on messages A, B and D is mandatory, thus these will remain in capital letters irrespective of hitting the [▲] or [▼] key.

Message;ABcDefgh

6. Again press the [ENT] key. Now the unit will proceed into the alarm mode after indicating the message "SET" for about two seconds.

S E T

7. In the alarm mode, either the message "AUDIO ALARM ON ?" or "AUDIO ALARM OFF ?" is displayed on the LCD window. These message may alternately be selected with the [▲] or [▼] key. To have the alarm sound when a D message is received, select "AUDIO ALARM ON?", then press [ENT].

Audio alarm ON?

Audio alarm OFF?

8. In order to turn off the alarm sound, press the [ENT] key.

ENT

ENT

The figure below shows an example of the NAVTEX message. The message always starts with the four characters "ZCZC" plus space, followed by the header code, then the main text and concludes with "NNNN".

```
ZCZC 0045
WZ 884
DOVER STRAIT
CABLE LAYING OPERATIONS IN PROGRESS BETWEEN FOLKESTONE AND SANGATTE
CABLE VESSELS LOCATED IN ENGLISH AND FRENCH INSHORE TRAFFIC ZONES
DETAILS IN REGULAR BROADCASTS BY CHANNEL NAVIGATION INFORMATION
SERVICE VHF10 DOVER VHF11 GRIS NEZ
CANCEL WZ 876 (0041)
NNNN
```

If any character in the header code is missing because the receiving condition is marginal, the printer will type an asterisk "*" onto the column of the lost letter.

Similarly if more than 33 percent of the characters of the main text are lost (the asterisk "*" is typed in place of the actual letter), the printing is stopped.

Note that the message having serial No. 00 (e.g., SAR message) is reprinted whenever it is received.

VERIFICATION OF NAVTEX STATION AND MESSAGE TO BE RECEIVED

You may verify the setting for NAVTEX reception (station and message ID) by the LCD display or the printer.

Press the [RCL/PRG] key and scroll the menu with the [▲] or [▼] key so that the message "Recall NAVTEX?" is displayed on the window. Hit [ENT], then an arrow key to obtain the desired display.

[▲] : Alternately changes the display to [▼] either station or message data.

[▶] : Scrolls the display to the left.

[◀] : Scrolls the display to the right.

To print out the setting for NAVTEX reception, first turn off the unit, then hold the [RCL/PRG] key while pressing the POWER button. Scroll the display with the [▲] or [▼] key to obtain the message "Print NAVTEX?", followed by pressing the [ENT] key. When the printing is completed, turn off the unit to escape from this mode.

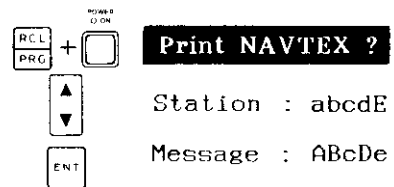
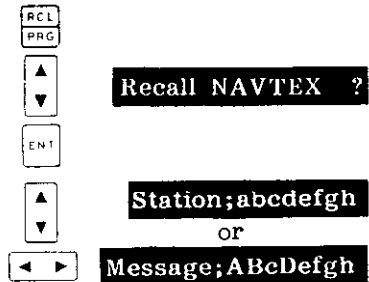

MONITORING THE NAVTEX SIGNAL

If necessary, you may monitor the NAVTEX signal instead of the facsimile signal.

Pressing the [MODE] key twice, either the message "Monitor FAX?" or "Monitor NAVTEX?" is displayed on the window. Select the message "Monitor NAVTEX?" with the [▲] or [▼] key (these keys alternately select the above messages), then hit the [ENT] key.

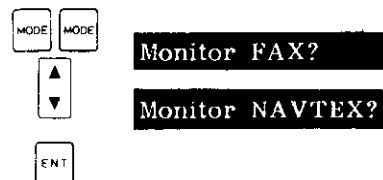

REPLACEMENT OF RECORDING PAPER

When the recording paper runs out completely, a distinct beep sound is released for about one second and the paper out alarm lamp lights to call the operator's attention. The message "PAPER OUT" also appears on the LCD display.

In the conventional facsimile receiver using a recording stylus, the operator must carefully note the remaining length of the recording paper since lack of paper may cause serious damage to the stylus. In most cases, shortage of paper will be acknowledged by an "end of roll mark" printed on the paper. The paper used in the DFAX also has a 50cm red end mark which appears when the paper remains about 1m. However, worry about damage to the stylus is eliminated since the unit employs a thermal head printer which automatically stops when the paper runs out.

1. Pull the paper container cover forward to open it.
2. Take out the paper spool with the spool catch pushed outward.
3. Take out the brims from the used spool and set it to a new roll of paper.
4. Cut both corners of the paper end to ensure smooth feeding.
5. Put back the paper in the paper container. Set the paper-release/lock lever to the release position, then insert the paper into the slot just above the container until the paper out alarm lamp goes off. Do not straighten the paper end, otherwise it will jam inside the cabinet.
6. Lock the paper with the paper-release/lock lever, then press the [σ] key to feed out the paper from the slot below the scale.
7. Tighten slack with the brims. Check that the paper is aligned evenly.
8. Press the [ENT] key to return to the normal display.

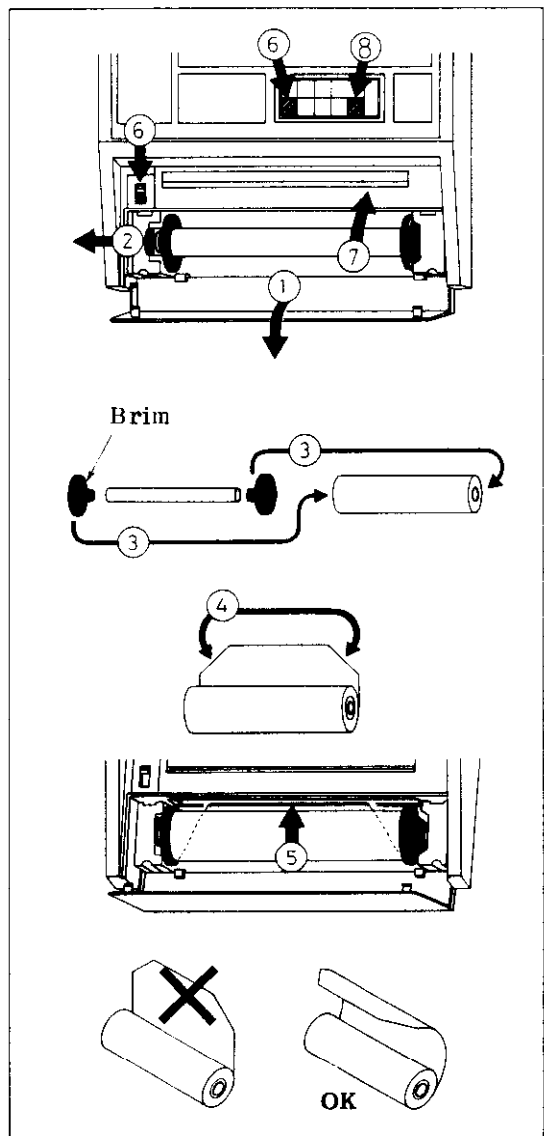

RECEPTION BY EXTERNAL RECEIVER

The unit requires no external receiver for normal use because most of the LF and HF weather facsimile broadcast frequencies have been programmed into the built-in memory. However you may also utilize a high performance external receiver when the signal level is marginal.

1. Connect the AF output of the external receiver to the EXT SIG terminal on the unit (Refer to page APB-1 for details). Generally the optimum level of AF signal (1mW/600ohms) may be taken from LINE OUT of the receiver. Adjustment of the AF signal level is very important. If the level is insufficient (less than 0.1mW) the unit will not operate, if it is too high (more the 10mW) the recorder circuitry may be damaged. In practice, it is essential to tune the receiver to the desired station first, then gradually increase the AF output to the rated level.
2. Set the MODE and BANDWIDTH selectors of the receiver to "CW" and "NARROW (approx. 1kHz)". Turn the RF GAIN control fully clockwise and set the AGC switch to "OFF". Place the BFO control at the mid point of its travel and set the receiver to the desired frequency. Adjust the VOLUME and BFO controls for a clear facsimile signal.

Note: To receive an LSB station, it may be necessary to shift the frequency up to ± 2 kHz relative to the assigned frequency.

3. Get the message "SPD/IOC xx/xx" on the LCD window by pressing the [MODE] key followed by the [ENT] key, and set the proper SPEED and IOC number referring to the Facsimile Schedule Book.
4. On completion of the SPD/IOC settings, press the [ENT] key to activate recording. Gradually increase the AF signal level so that the picture is plotted on the recording paper. If necessary, readjust the BFO control for a clear recording.
5. When interference or noise is heavy, try to shift the TUNING dial up to ± 300 Hz from the assigned frequency to obtain a better picture. A narrower bandwidth is better for rejecting noise. However if the resolution of picture becomes poor, select a wider bandwidth.

MAINTENANCE

GENERAL

The equipment will maintain optimum performance for a reasonably long period. However, continued performance can not be expected without periodic inspection and maintenance. Important points to be checked from time to time are tabulated below.

Check Item	Action
whip antenna	If cracked or broken, replace it with a new one.
antenna wire	If sheath peelen, seal with vinyl tape. If immersed with water, stretch new antenna wire.
junction of whip antenna and preamp unit	If corroded, clean and waterproof with sealing compound.
coaxial cable	If cut, repair it.
coaxial plug connection	If loosened, reconnect. If corroded, clean contacts.
power plug connection	If loosened, reconnect. If corroded, clean contacts.
battery connection	If corroded, clean power terminals.
grounding terminal	If corroded, clean terminal.

FUSE REPLACEMENT

To protect the equipment from serious damage, two fuses are provided on the power supply lines.

The fuses protect against over-voltage/reverse polarity of the ship's mains or internal fault of the equipment.

If a fuse has blown, first find out the cause of the trouble before replacing it with a new one. A fuse rated for more than 7A should not be used, since it may cause permanent damage to the equipment.

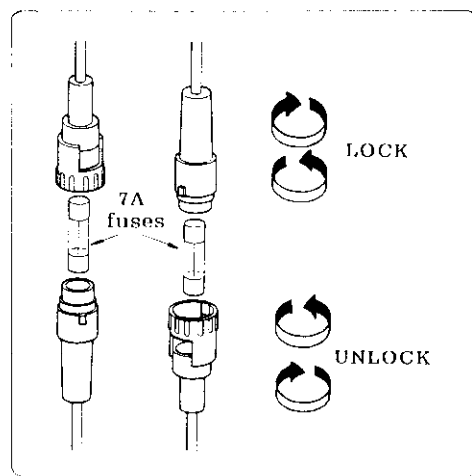

Damage due to overfusing is not covered by the warranty.

Another fuse is provided inside the equipment (POWER module), and it blows when the internal circuit is defective. If this happens, call your dealer for service. Never attempt further circuit check inside.

CLEANING

The unit should be kept clean and dry at all times. Dust or loose dirt can be wiped off with a soft and dry cloth. To remove thick and heavy dirt, use a mild detergent and water on a soft cloth.

CAUTION

Never use plastic solvents, such as thinner or acetone, for cleaning. It may harm the cabinet case, touchpads and the display window.

Cleaning of Thermal Head

Though the thermal head of printer is capable for printing out more than 60 rolls of paper, the print contrast may suddenly deteriorate if debris accumulates on the surface of thermal head. To remove such debris, use cleaning pen (Code No. 000-115-199) supplied. We recommend to clean the thermal head after every 3 to 5 rolls of paper is consumed.

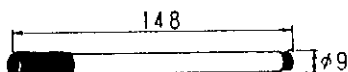

- 1) Open the paper container and remove three self-tapping screws $\phi 4 \times 12$.
- 2) Lift up the top cover.
- 3) Clean the thermal head with the cleaning pen.
- 4) Refasten the top cover and paper container.

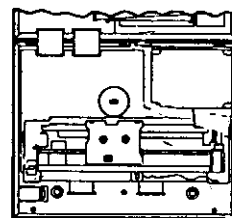
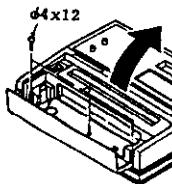

TROUBLESHOOTING

OPERATOR TROUBLESHOOTING

Problems with the equipment may be caused not only by a faulty circuit but also by the incoming signal condition, inadequate installation, or even operator error.

The list below shows the typical troubles which may be mistaken as equipment error.

SYMPTOM	POSSIBLE CAUSE	REMEDY
Power won't come on. (No display nor sound)	<ol style="list-style-type: none"> 1. Switch at main switchboard is turned off. 2. Power connector is loose or pulled out. 3. Power fuse (7A) has blown. 4. Battery is dead. 	<ol style="list-style-type: none"> 1. Turn on the main switch. 2. Plug connector firmly. 3. Check mains voltage and polarity first, and put a new fuse. If it blows again, call for service. When driven from AC mains, check rectifier as well. 4. Charge or replace battery.
Lamp lights but no or faint display.	<ol style="list-style-type: none"> 1. Improper CONTRAST setting 	<ol style="list-style-type: none"> 1. Adjust the CONTRAST control. (Ref. page 14.)
Unreadable character displayed	<ol style="list-style-type: none"> 1. Back-up memory contents destroyed. 2. Keep-alive battery is dead. 	<ol style="list-style-type: none"> 1. Perform "Cold Start." (Ref. page 13.) 2. Ask your dealer for battery replacement.
No audible sound	<ol style="list-style-type: none"> 1. VOLUME is set too low. 2. Loop-back jumper wire(s) at rear terminal board is disconnected. 	<ol style="list-style-type: none"> 1. Adjust the VOLUME control. (Page 16) 2. Connect the jumpers correctly. (#2 - #3 & #5 - #6)
Noise sound but no or very weak signal	<ol style="list-style-type: none"> 1. Antenna connector is loose or disconnected. 2. Antenna cable is cut or shorted. 	<ol style="list-style-type: none"> 1. Fasten it tightly. 2. Repair the cable.
No response to key operation	<ol style="list-style-type: none"> 1. Recorder is in sleep mode ("OFF Facsimile"). 	<ol style="list-style-type: none"> 1. Press [MODE] to restart. (Page 19)
Can't start recording.	<ol style="list-style-type: none"> 1. Paper has run out. (PAPER OUT lamp is on.) 	<ol style="list-style-type: none"> 1. Load a new roll of paper. (Page 29)

- cont -

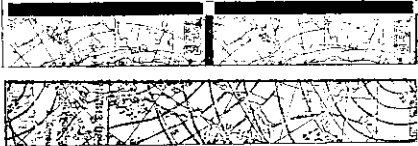
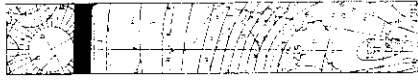
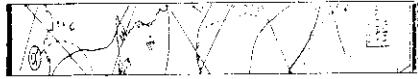
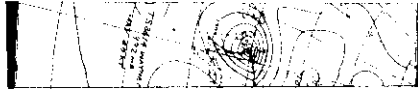
SYMPTOM	POSSIBLE CAUSE	REMEDY
Paper won't advance.	<ol style="list-style-type: none"> 1. RELEASE/LOCK lever is in "RELEASE" position. 2. Paper is jammed. 3. Paper roll has slipped out of supporting catches. 	<ol style="list-style-type: none"> 1. Turn the lever to "LOCK" side. 2. Clean paper path. 3. Load paper correctly. (Ref. page 29.)
Paper feeds but no recording.	<ol style="list-style-type: none"> 1. Paper is loaded with front-side-back. 2. Normal paper (non-thermal) is used. 	<ol style="list-style-type: none"> 1. Load paper correctly. (Ref. page 29.) 2. Use specified thermal paper.
Multiple or overlapped picture	<ol style="list-style-type: none"> 1. Speed mismatch 	<ol style="list-style-type: none"> 1. Select correct speed. (Ref. page 17.)
Split picture (Dead sector in the middle)	<ol style="list-style-type: none"> 1. Out of phase 	<ol style="list-style-type: none"> 1. Set PHASE manually. (Ref. page 18.)
Vertically expanded or compressed picture	<ol style="list-style-type: none"> 1. IOC mismatch 	<ol style="list-style-type: none"> 1. Change IOC manually. (Ref. page 17.)
Skew picture	<ol style="list-style-type: none"> 1. SYNC is deviated. 	<ol style="list-style-type: none"> 1. Adjust SYNC control. (Ref. page 19.)
Faint or noisy picture	<ol style="list-style-type: none"> 1. Receiver detuned 2. Weak incoming signal 	<ol style="list-style-type: none"> 1. Adjust frequency manually while watching TUNE indicator. (Ref. page 16.) 2. Select another frequency.
Won't start recording as scheduled.	<ol style="list-style-type: none"> 1. Remote start mode is selected but start signal is not transmitted. 2. Improper schedule setting (Two programs overlapped in time - later schedule will be disregarded.) 	<ol style="list-style-type: none"> 1. Use time start mode if dead sector is transmitted in black. 2. Review schedule.
Schedule and private channel settings are cleared or destroyed.	<ol style="list-style-type: none"> 1. Keep-alive battery for memory back-up is dead. 	<ol style="list-style-type: none"> 1. Ask your dealer for battery replacement. Perform "Cold Start" Sequence. (Page 16)
Paper turned black	<ol style="list-style-type: none"> 1. Paper has been stored in hot environment or exposed to active chemical gas. 	<ol style="list-style-type: none"> 1. Keep paper in dry and cool place.

SELF-TEST

To aid you in tracing down a defective circuit block inside the equipment, the DFAX contains a self-test function. As this test is intended for use by service personnel, do not attempt further circuit check inside even if the faulty block can be identified.

Prior to starting the self-test, make sure that the mains voltage is within the rated range (10 to 40Vdc) and the power fuses (7A) are not blown. Check also that the recording paper is loaded correctly.

To start the test, press the POWER switch while holding down the [MODE] key.

LCD READOUT

PRINTOUT

Self Test * Hold down the [MODE] key until you see "Self Test."

Prints program version number and copyright message.

```
< * DFAX * >      Program No. 8859-1111-98
FURUNO Electric Co.,LTD. Japan 1986.7
```

* Program No. (and the date of issue) is subject to change.

Test Printer

Prints complete character set.

```
----- Printer CPU Self Test -----
abcdefghijklmnopqrstuvwxyz0123456789 *()*+,-./:;=?
ABCDEFGHIJKLMNOPQRSTUVWXYZ0123456789 *()*+,-./:;=?
```

Test FAX

Prints four-tone checker pattern.

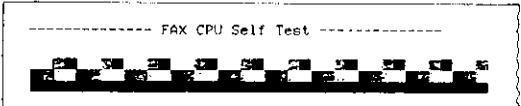

Puts PHASE and SPEED LEDs on.

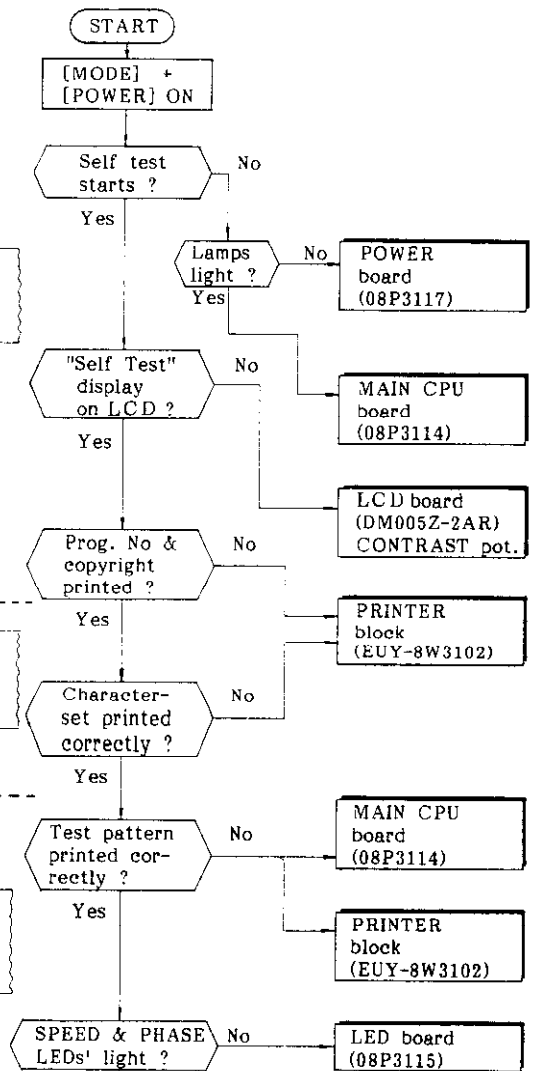

Test NAVTEX

(Available on Navtex version only)

Checks ROM/RAM on NAV RCV board and performs local loop-back test. (Frequency-shift tone can be heard.)

```

----- NAVTEX Self Test -----
ROM Test OK
RAM Test OK
ABCDEFGHIJKLMNPOQRSTUVWXYZ 0123456789
NAVTEX Signal Send and Receive (Local Loop Test)
ZCZC IE01
ABCDEFGHIJKLMNPOQRSTUVWXYZ 01234567890
NNNN
    
```

message sent (generated internally)
message received

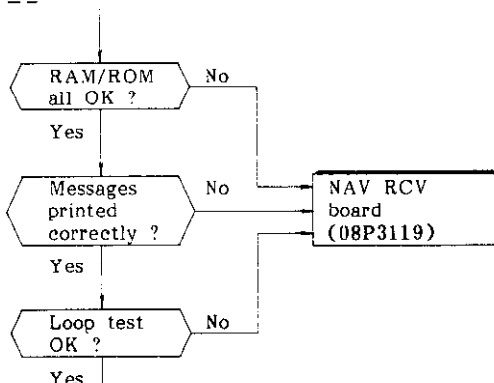

Test Master

Checks RAM/ROM for master CPU. Lights all LEDs on front panel.

```

----- Master CPU Self Test -----
Internal RAM OK
External RAM OK
ROM OK
(FAX Receiver Test)
5000.0 kHz Sense-Level = 9
10000.0 kHz Sense-Level = 9
15000.0 kHz Sense-Level = 7
    
```

Receives standard time signal (WWX, JJY, MSF, ZUO, etc) at 5, 10 and 15MHz and prints each signal level (0 to 9). If abnormal, signal level will be 0, 1 or 2.

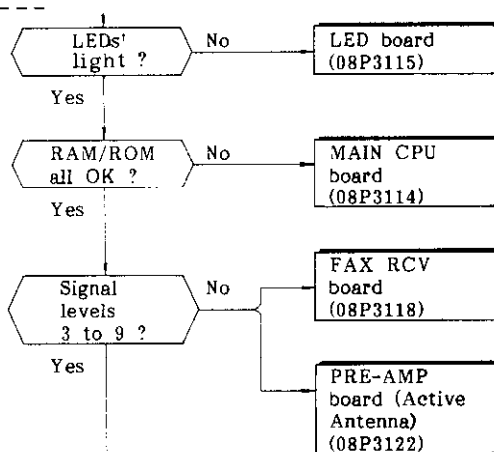

Push ENT

- * Press the key as the LCD readout prompts.
- * If the key operation is accepted, a beep is generated and the readout shows the next key to be pressed.

Push PHASE

All key OK

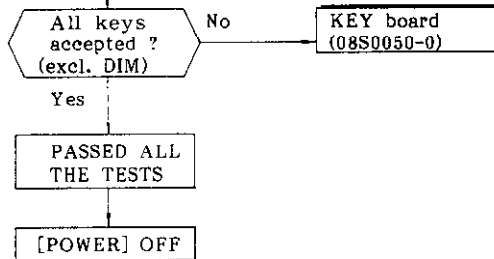

End of Self Test

END

PARTS LIST FOR FAX-208A/N

SYMBOL	NAME	TYPE	CODE	REMARKS
A101	CONTAINER COVER	08-008-0105	100-059-272	
A102	SPOOL BRIM ASSY		007-901-610	
A103A	KNOB	03-016-1203	000-104-541	
A103B	SPRING	No. 6601	000-800-604	
A103C	PACKING	03-016-1205	100-030-120	
A104	POWER BOARD	08P3117	007-901-350	
A105	PRINTER ASSY	EUY-8W3102	000-108-127	
A106	MAIN CPU BOARD	B08P3114	007-901-520	
A107	EPROM	FAX-208A/N	007-901-250	
A201	LED BOARD	08P3115	007-901-600	
A202	SPEAKER	SI33D03	000-108-151	
A203	VR BOARD	08P3116	007-901-550	
A204	KEY LED BOARD	08P3125	007-901-590	
A205	KEY BOARD	08S0050	000-108-126	
A206	LCD BOARD	DM005Z-2AR	000-108-125	
A207	PWR SW BOARD	08P3124	007-901-540	
A301	NAV RCV BOARD	08P3119	007-901-580	OPTION
A302	FAX RCV BOARD	08P3118	007-901-570	
A303	2P TERMINAL	238-402	000-108-122	
A304	8P TERMINAL	238-408	000-108-123	
A305	POWER CONNECTOR ASSY	08S0061-1	000-108-136	
A306	TB COVER	08-008-0149	100-059-502	
A307	ANTENNA CONNECTOR ASSY	08P0060	000-108-253	
A308	TERMINAL BOARD	08P3121	007-901-530	
A401	PREAMP BOARD	08P3122		OPTION

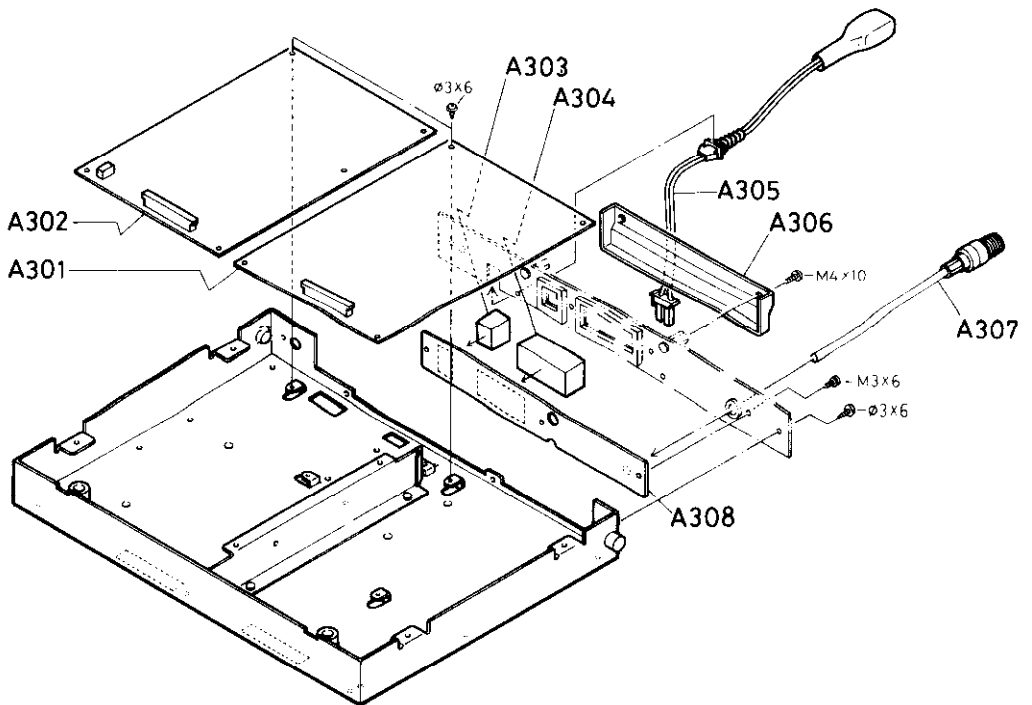
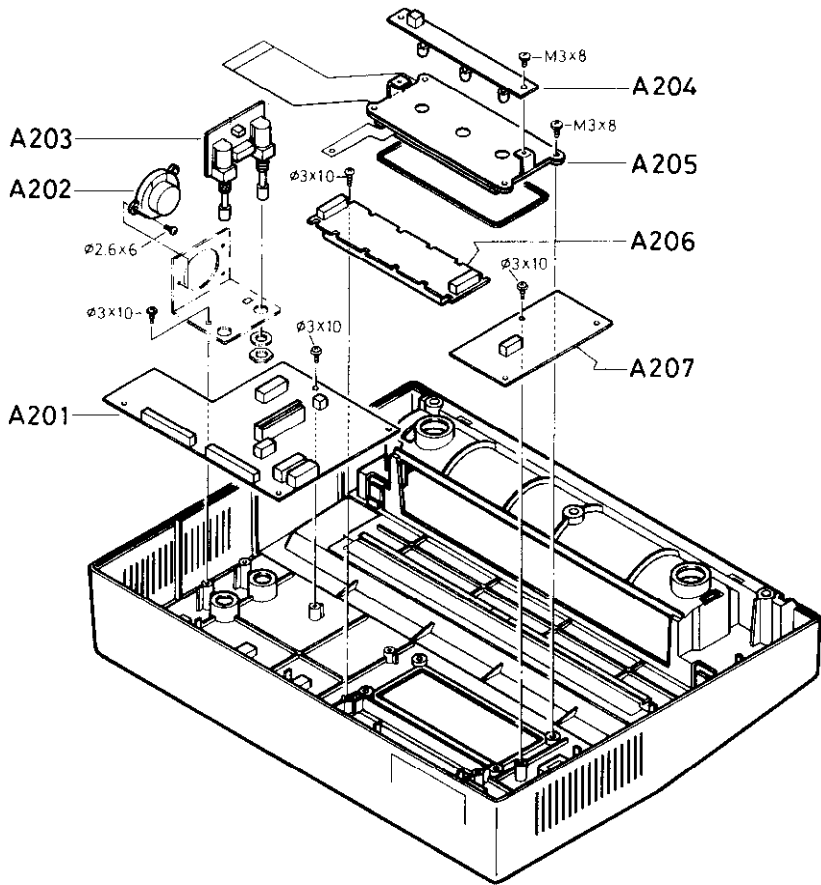

**TITLE: FAX-208/A/N
FACSIMILE RECEIVER**

DWG. No. E6243-003-A

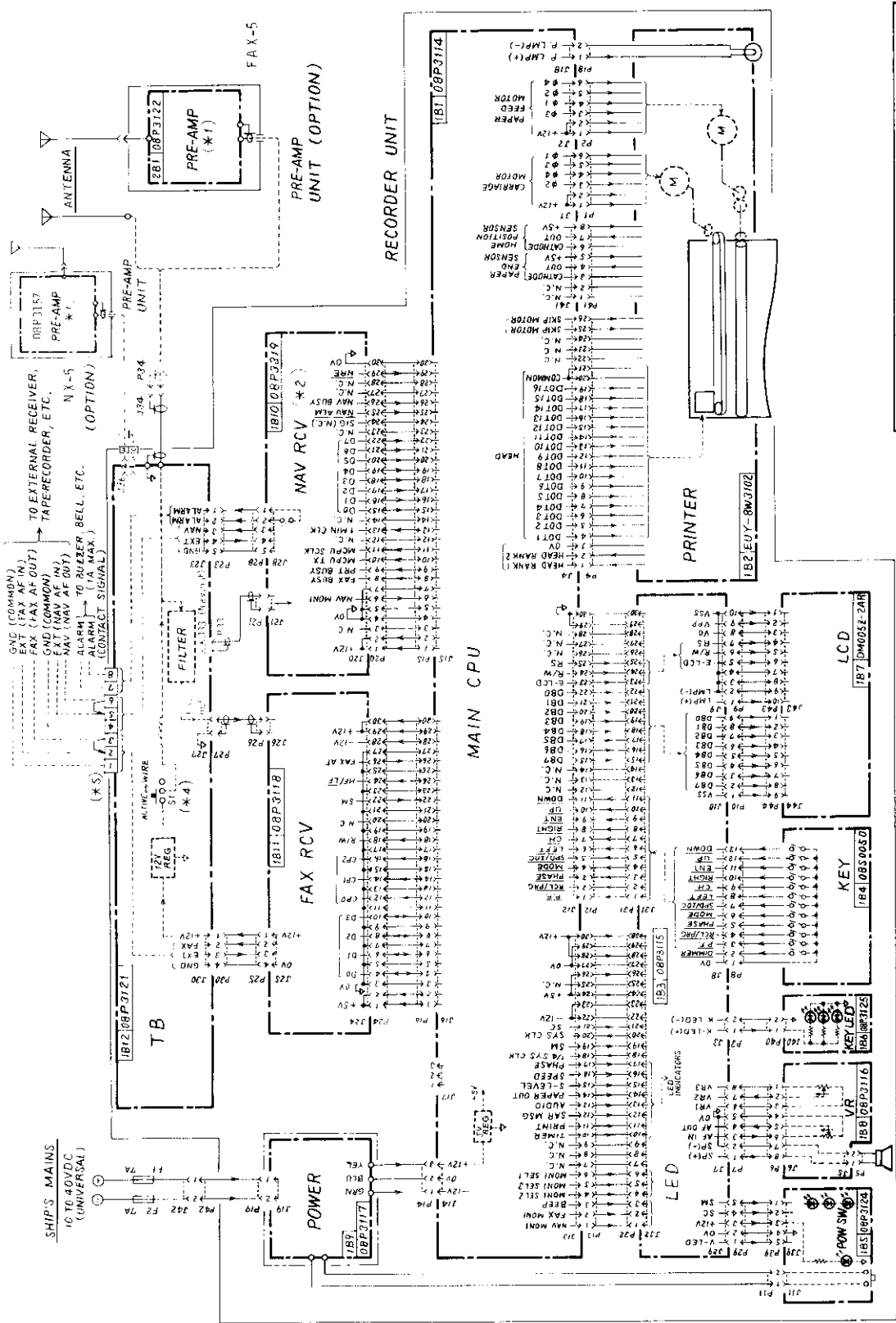

TITLE: FAX-208/A/N
GENERAL SCHEMA.
DWG. NO. E6243-001-D

NOTE: * 1 OPTIONAL SUPPLY.
 * 2 FAX-208.....NAV RCV CAN NOT BE INCORPORATED.
 * 3 FAX-208A.....NAV RCV OPTIONAL SUPPLY.
 * 4 SET S1 TO "ACTIVE" SIDE IF EQUIPPED WITH ACTIVE ANTENNA. OTHERWISE, SET IT TO "WIRE".
 * 5 TO USE BUILT-IN RECEIVERS, CONNECT AF LOOP-BACK LINKS (2+43 AND 3+46).

POWER **VOLUME** **SYNC**

(SHIELD CASE)

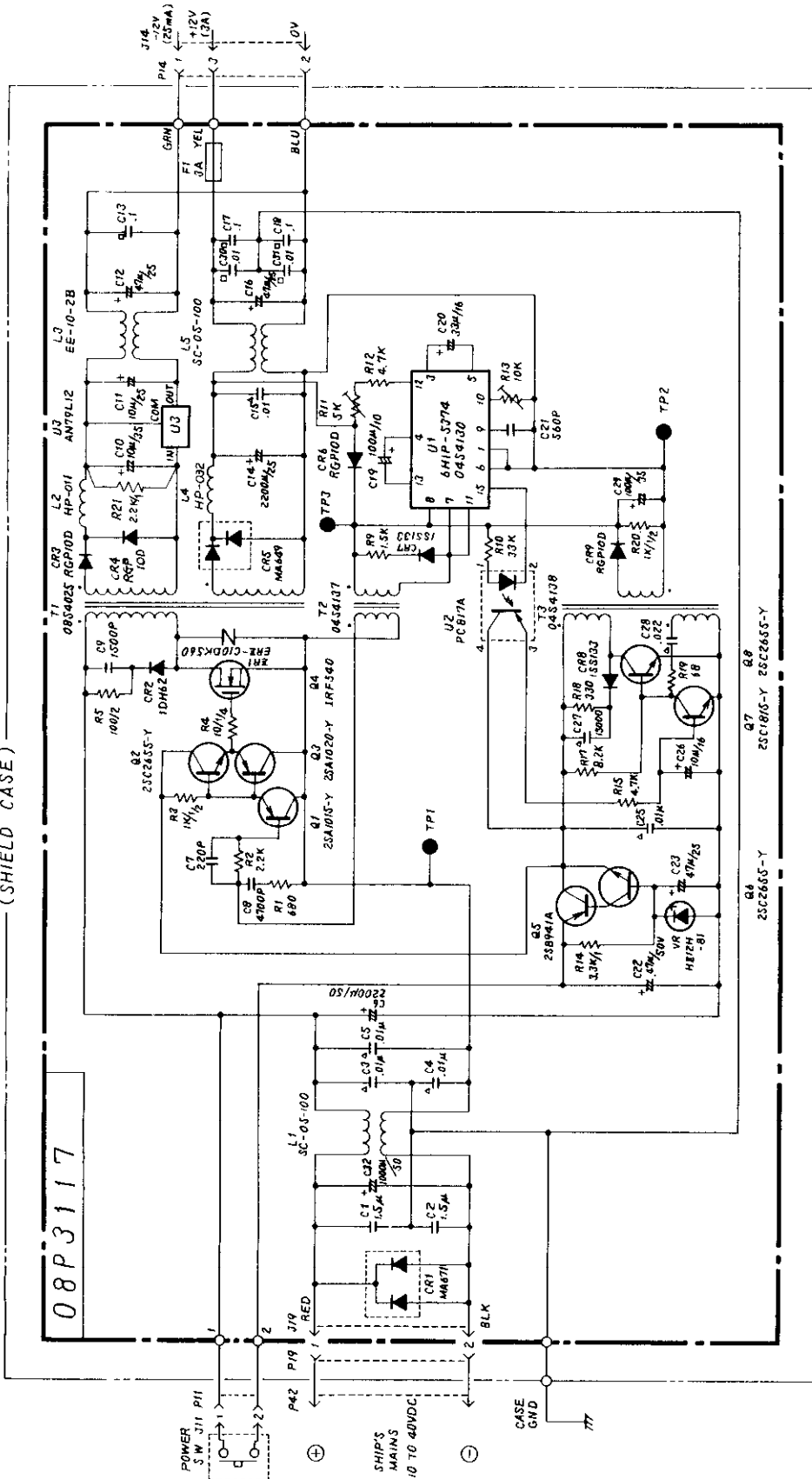

08P3117

NOTE 1. UNLESS OTHERWISE NOTED, RESISTANCE IN OHMS (1/6W) AND CAPACITANCE IN FARADS.
 2. "Δ" DENOTES POLYPROPYLENE CAPACITOR.
 "□" DENOTES CERAMIC CAPACITOR.

TITLE: POWER SUPPLY MODULE
 DWG. No. E6243-002-A

SPECIFICATIONS

RECORDER SECTION

Recording system:	Parallel thermal head recording system
Scanning speed:	60, 90, 120 and 240 on full scale
Index of cooperation: (I.O.C.)	576 (fine) and 288 (rough)
Line density:	5 lines/mm approx.
Gradation:	Four levels; white, light gray, dark gray and black
Recording controls:	a. Start/stop Automatic by schedule timer and/or WMO remote control signals, or Manual (schedule timer - 16 programs/day) b. Scanning speed Automatic or Manual c. I.O.C. Automatic by WMO start signals or Manual d. Phase matching Automatic by line sync. signal or Manual
External input signal:	Black 1500Hz, white 2300Hz FSK signal (signal level; 0 dBm at 600 ohms)
Recording paper:	Thermal paper TP-0820, 216mm(W)x20m(L) effective width 192mm

RECEIVER SECTION

Frequency range:	LF 80kHz to 160kHz and MF/HF 2MHz to 25MHz both in 100Hz steps
Number of channels:	371 channels (357 existing facsimile frequencies plus 14 user frequencies; all re-programmable by operator)
Frequency selection:	Automatic channel search for highest signal strength within a selected zone/station Manual selection of zone, station and channel number Manual tuning by frequency up/down keys
Tuning indication:	Flow-up/flow-down (detuned) and steady (tuned) by three LED's
Class of emission:	F3C, J3C (USB/LSB programmable)
Receiving sensitivity:	LF: better than 10uV at 20dB SINAD MF/HF: better than 2uV at 20dB SINAD
Selectivity:	2.6kHz at -6dB 8kHz at -60dB

GENERAL SPECIFICATIONS

Power supply: 10 to 40Vdc universal
100/110/220Vac with separate rectifier PR-62

Power drain: Stand-by; less than 15W (1.2A at 12Vdc)
Recording; less than 27W (2.2A at 12Vdc)

Dimensions: 340(W) x 270(H) x 115(D) mm approx.

Environmental condition: -15°C to +55°C

NAVTEX RECEIVER SECTION

Receiving frequency: 518kHz

Station and message selection: On/off selection of station and message by keypad

Message memory capacity: 7000 characters
30 identification codes

Message holding time: 66 hours after reception

Alarm indication: Audible and visible (LED) indications for SAR message reception

Minimum antenna input: (for message capture) Less than 2uV for 50 ohm antenna or
less than 5uV for 150pF + 10 ohm reactive antenna

Interference rejection: Error rate less than 4% with desired signal of 20dBu and interference signal of 14dBu

Intermodulation: Better than 70dB for 4% error with desired signal of 20dBu

Spurious emission: Less than 1nW

Number of column: 79 characters/line

Character construction: 13 x 9 dot matrix

Character set: Letters, numbers and symbols

Print speed: 27 characters/second

Applicable standards and regulations: Complies with; CCIR rec. 476-3,
CCIR rec. 540,
CEPT, MPT 1257

PREAMP UNIT (Active Antenna)

Frequency range: 80kHz to 30MHz

3rd order output intercept: +23dBm

Input protection: Protected against 30Vrms antenna input for 15 minutes

Output Impedance: 50 ohms

COMPASS SAFE DISTANCE

Master	Steering
0.8m	0.4m

COMPLETE SET

No.	Name	Type	Code No.	Q'ty	Remarks
1	Recorder Unit	FAX-208	000-075-009	1 set	Fax only
		FAX-208A	000-075-010		Fax only (Navtex option)
		FAX-208N	000-075-011		Fax plus Navtex
2	Installation Materials	CP08-00600	000-075-014	1 set	See separate list below.
3	Spare Parts	SP08-00510	000-075-013	1 set	See separate list below.
4	Option				See separate list below.

INSTALLATION MATERIALS

No.	Name	Type	Code No.	Q'ty	Fig.	Remarks
1	Power Cable	08S0062-2	000-108-137	1	1	2x7A fuses fitted
2	Grounding Wire	08S0087-0	000-108-138	1	2	
3	Connector	FM-MP-7	000-108-859	1	3a	RG-8/U, -213/U
	Reducer (L)	MP-M5A	000-108-861	1	3b	RG-5/U, -212/U
	Reducer (S)	MP-M3A	000-108-860	1	3c	RG-55/U -58/U
4	Tapping Screw	ø5 x20	000-802-081	4	4	

1

2

3

4

SPARE PARTS/ACCESSORIES

No.	Name	Type	Code No.	Q'ty	Fig.	Remarks
1	Fuse	FGMB 3A 125V	000-104-909	2	1	+12V line output
2	Fuse	FGBO 7A 125V	000-549-013	4	2	Mains input
3	Hook Spanner	238-332	000-108-139	1	3	Clipper terminal opener
4	Recording paper	TP-0820	000-801-053	(2)	4	One contained in recorder
5	Thermal head cleaner	OWP-FD-6AI-01	000-115-199	1		

1

2

3

4

OPTION

No.	Name	Type	Code No.	Q'ty	Remarks	
1	Preamp Unit	FAX-5	007-901-930	1		
2	Antenna Fixture	CP08-00610	007-901-940	1		
3	Whip Antenna	04S4176	000-112-845	1	2.6m	
4	Coaxial Cable Kit	OP04-2, 10m	000-041-174	1	For extension of antenna cable (with connectors)	
		OP04-2, 20m	000-041-175			
		OP04-2, 30m	000-041-176			
		OP04-2, 40m	000-041-177			
		OP04-2, 50m	000-041-178			
5	Rectifier	PR-62 100VAC	000-013-484	1	For AC mains	
		PR-62 110VAC	000-013-485			
		PR-62 200VAC	000-013-486			
		PR-62 230VAC	000-013-487			
6	Navtex Kit	OP08-2	000-075-015	1 set	For FAX-208A	
7	Whip Antenna	08S0250	000-130-046	1	1.2m	
8	Preamp Unit	NX-5-N-0	000-040-248	1	No coaxial cable	For Navtex Receiving
		NX-5-N-10	000-040-241		w/10m coaxial cable	
		NX-5-N-20	000-040-242		w/20m coaxial cable	
		NX-5-N-30	000-040-243		w/30m coaxial cable	
		NX-5-N-40	000-040-244		w/40m coaxial cable	
		NX-5-N-50	000-040-245		w/50m coaxial cable	
9	Power Cable	CP08-01000	000-003-290	1	w/noise filter	
10	Hose Clamp	SS7200N	000-570-239	2	Clamp for fixing preamp	

HOW FACSIMILE SYSTEM WORKS

The picture on a TV screen consists of many fine horizontal lines. This is because of its transmission system that a frame of picture is sliced into narrow strips and sent piece by piece serially to a receiving station, where the strips are reassembled to reconstruct the original picture. As the frequency band assigned for TV broadcasting is comparatively wide, 25 or 30 frames of pictures can be sent in a second.

The radio facsimile uses much the same principle as the TV broadcasting system, but in a lower frequency and in a narrower bandwidth. Due to this limitation, it takes several minutes for the facsimile transmitter to send a frame of picture.

Though the transmission speed is slower than that of the TV, the facsimile signals in LF or HF bands propagate at much greater distances than the normal TV signal.

Radio facsimile system

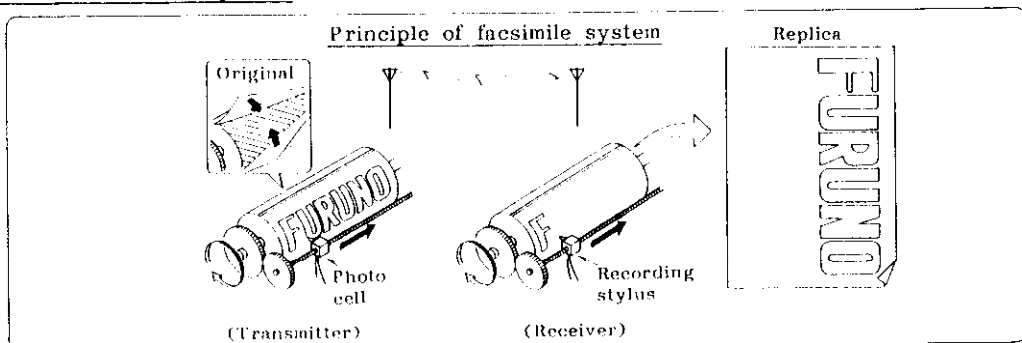

At the facsimile transmitter, the original picture is fitted on a drum rotating at 60, 90, 120 or 240 rpm, and a photo cell mounted on the threaded shaft moves slowly along the drum. The photo cell, focused on a point on the drum, converts black and white information into an electrical signal. As the drum rotates and the photo cell moves, the picture information is sliced into narrow pieces and a series of black and white signals are obtained. In the transmitter, the black and white signals are converted into 1500Hz (black) and 2300Hz (white) frequency shifts and modulates the radio frequency assigned for the station. (The black and white frequencies will be reversed in the LSB transmission.)

At the receiver, the frequency shift (FS) signals are converted into a black and white recording signal and the marks are printed on the recording paper.

To obtain an exact copy of the original picture at the receiver, the rotating speed and phasing of the transmitter and receiver must agree with each other, i.e., synchronization in rotation and synchronization in position.

To achieve automatic synchronization, most transmitters transmit a phasing signal before sending pictures. The phasing signal is a continuous black signal with narrow white gaps at the seam of the original picture. In the automatic facsimile receiver, the repetition rate and position of the white gaps are detected to determine rotating speed and phase.

In addition to the speed and phase synchronization, the line density with respect to the picture width for the transmitter and receiver must agree with each other to obtain an exact copy of the original picture. Otherwise the reproduced picture may be expanded or compressed vertically. To maintain international compatibility, two line density standards are assigned by WMO; high density - IOC 576 and low density - IOC 288.

IOC stands for Index Of Cooperation, and indicates the horizontal/vertical ratio of a picture. In practice, it is the product of line density and drum diameter.

$$\text{IOC} = (\text{line density}) \times (\text{drum diameter})$$

OR

$$\text{IOC} = \frac{(\text{line density}) \times (\text{picture width})}{\pi}$$

To enable fully automatic start and stop of picture recording, most facsimile transmitters send remote start and remote stop signals before and after transmission of pictures. The remote signals appear as black/white stripes as shown right.

For identification of start, stop and line density of picture transmission, three frequencies are used as remote signals. The start signal is either 300Hz or 675Hz to indicate the line density of the forthcoming picture. The remote stop signal is always 450Hz.

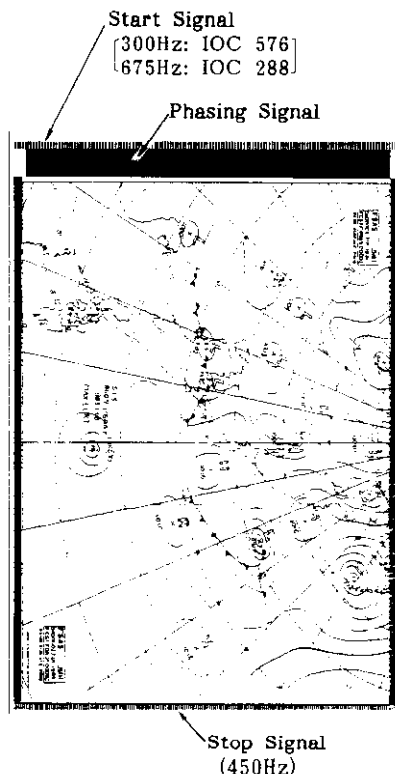

Recording system on DFAX receiver

The recording system used in DFAX is somewhat different from conventional recorders.

The received signal is first stored and assembled in the memory according to the given speed, phase and IOC. It is then printed out by the parallel printer head when a certain amount of picture information is accumulated in the memory. For IOC 576, one piece of the picture, corresponding to approximately 30 scan lines of incoming signal, is printed at a time.

Picture recording is performed by controlling the temperature of each thermal element rapidly while moving the parallel head on the recording paper. Depending on the temperature, chemical material on the paper changes the color of the paper and reproduces picture.

HOW NAVTEX WORKS

There are many types of navigational and meteorological information available on radio such as NAVAREA, HYDROPAC, etc. However, these systems rely heavily upon the operator's experience and skill in tuning the radio and interpreting messages. In addition, constant monitoring to pick up wanted information among a vast volume of messages is not practical with a limited radio staff.

To provide all mariners with up-to-the-minute information automatically, the Navtex system was developed.

NAVTEX is an acronym meanings Navigational Telex, and as its name shows, it is a kind of narrow band radio teletype system for sending (by frequency shift keying) text messages expressed in a 7-unit code. The difference between the conventional narrow band teletype system and the Navtex is that a Navtex transmitter transmits nine control characters (header code) ahead of the main message, so that the receiver can identify the station, message type and serial number automatically.

Navtex system operation

For navigation purposes, the world is divided into 16 areas as shown in the figure below. Each Navtex station in each area has an identification code, from "A" to "Z."

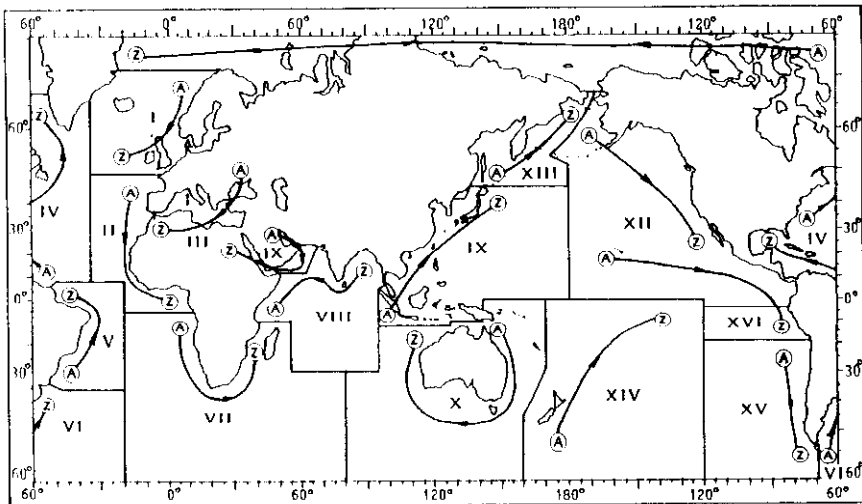

The frequency assigned to Navtex is only one (518kHz), and many stations exist in the same service coverage. If the stations were to transmit without any rule, the system would collapse due to mutual interference. To avoid this problem, the following rules apply.

- The transmission schedule is determined so that two or more stations having a common service area may not overlap in time.
- Each station transmits with minimum required power to cover its service area (200 nautical miles nominal).

[**Type of message** (category)]

A:	Coastal navigational information	H:	Loran-C message
B:	Meteorological warning	I:	Omega message
C:	Ice report	J:	Differential Omega message
D:	Search and rescue alert	K:	Other electronic nav. system message
E:	Meteorological forecast	L:	NAVAREA warning
F:	Pilot message	M-Y:	No category assigned
G:	Decca message	Z:	QRU (no message on hand)

APPENDIX B. EXTERNAL CONNECTIONS AND INTERNAL PRESETS

EXTERNAL INPUT/OUTPUT

At the rear panel of the recorder unit, 8P and 2P terminal boards are provided for connecting external equipment.

No.	Symbol	Purpose	Condition	Connected to;
1 2	RX-C RX-H	Additional navtex antenna input (Ref. to page APE-1.)	NAV RCV PCB installed	NX-5 (Preamp)
1 2 3	GND EXT FAX	Fax ground Fax AF input Fax AF output	0dBm, 600 ohms	All-wave receiver, tape recorder, etc.
4 5 6	GND EXT NAV	Nav ground Nav AF input Nav AF output		
7 8	ALM	Contact signal (ON: SAR received)	1A dc, 20W max.	Buzzer, bell, etc.

Connections to these clipper terminals (spring-loaded) can be made by using the special hook spanner, provided as spare parts.

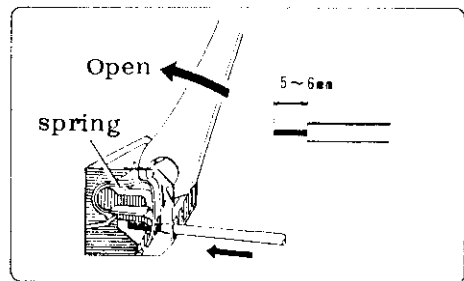

Facsimile and Navtex signal input/output

In the DFAX, the receiver and the recorder sections are independent of each other. That is, the audio signals (frequency shift tone) from the internal facsimile and Navtex receivers are output to terminals #3 and #6, and they are usually fed back to respective recorder input terminals #2 and #5 through the external loop-back links. (Terminals #1 and #4 are common ground for facsimile and Navtex signals respectively.)

If a signal is available from an external all-wave receiver, its audio output may be connected to the recorder input of this unit. The figure below shows an example connection for an external receiver.

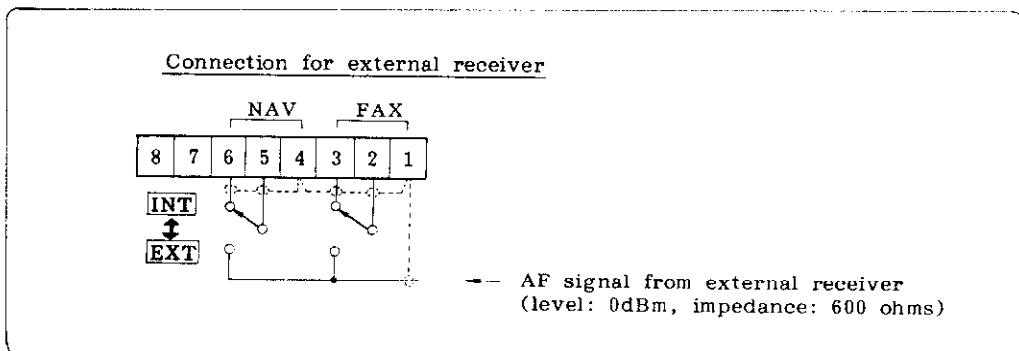

The external input/output terminals may also be used for tape recording and play-back of Navtex messages. The figure below shows an example connection for the record/playback system. Note that the tape running speed must be accurate and stable enough to obtain correct Navtex messages.

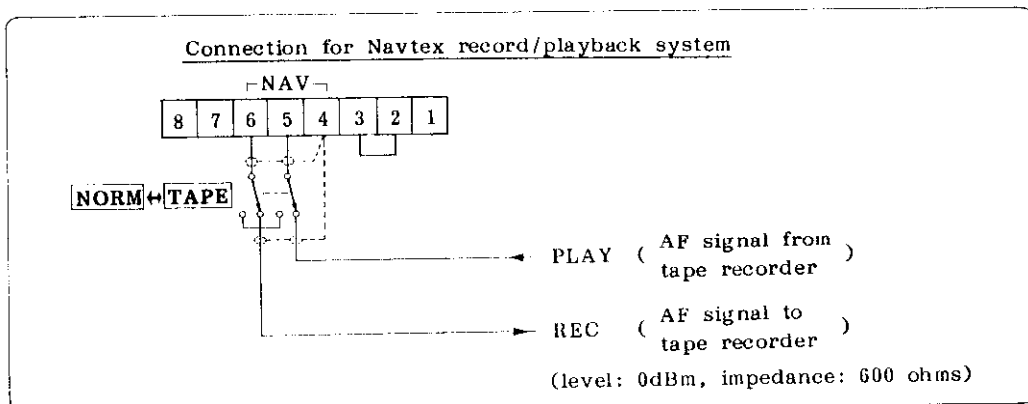

CAUTION

Don't forget to install loop-back links between terminals #2 and #3, and #5 and #6 when no external equipment is connected, otherwise normal recording will not be available.

Navtex alarm output

Terminals #7 and #8 are contact closure type output to alert that a search and rescue (SAR) message is being received on Navtex. If it is necessary to signal the situation in a louder sound level than the built-in speaker or by some other means, such as a flashing light or a prerecorded tape, use this contact signal. The relay contact is capable of handling a 1A/20W load.

To maintain good receiving condition, the device connected to the alarm terminal should not generate radio noise. (A poor quality electric buzzer may cause heavy radio noise due to arcing at its contact.)

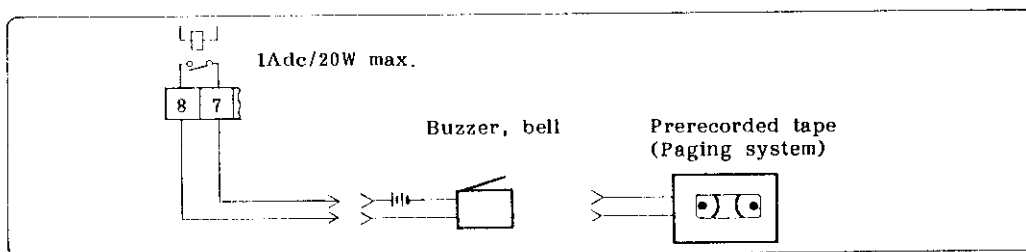

External break-in relay

In some cases where the DFAX is installed on a boat equipped with a high power MF/HF transmitter (200W or more), there is a possibility of induced high power RF signal on the DFAX antenna.

If the Pre-amp Unit (active antenna) is installed, there is no need of protection against an RF induction, since the unit is designed to withstand against a 30Vrms antenna input for at least 15 minutes.

However, if a long-wire antenna and/or a whip antenna is directly connected to the DFAX receiver, a high power RF induction may well damage its front-end. An external break-in relay should then be installed in the DFAX antenna line as shown below.

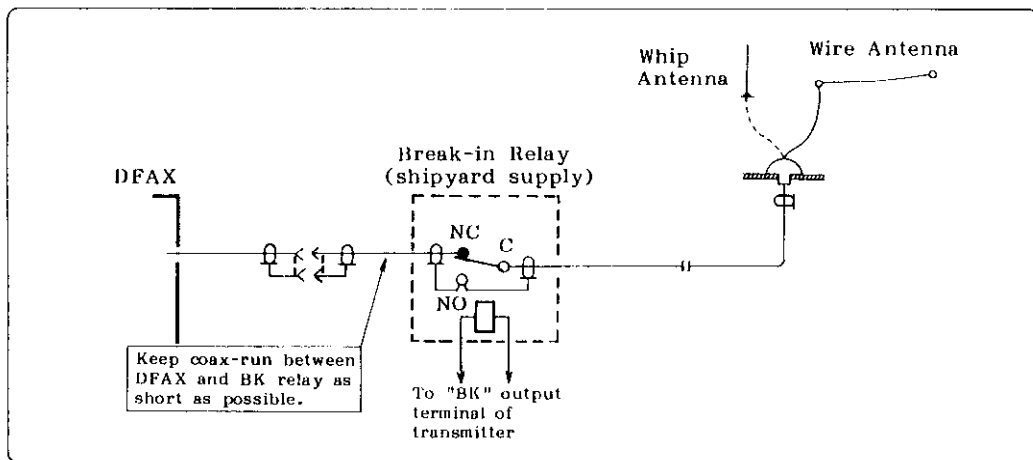

A relay should be connected so that the antenna is disconnected from the DFAX and connected to ground when the transmitter is keyed.

The voltage rating of the relay should be determined by the requirements of the transmitter.

NOTE

The NAVTEX provides its intended performance when it is received continuously. Unlike facsimile reception, even a short break can destroy reception of one complete NAVTEX message.

It is, thus, strongly recommended to install the Pre-amp Unit (active antenna) and to place the DFAX antenna far apart from transmitting antenna if NAVTEX is mandatory for your navigation.

HOW TO CHANGE INTERNAL SETTINGS

To allow custom tailoring of the unit to specific user's needs, a preset switch and a potentiometer are provided inside the recorder unit. Prior to accessing any internal component, remove the recording paper and disconnect the power plug.

Print intensity

If the operator prefers a darker or more lighter recording than the factory setting, and also when the thermal head is replaced with a new one, change the setting of the internal switch as described below.

1. Open the paper container and remove the three self-tapping screws ($\phi 4 \times 12$) as shown below.
2. Gently lift up the top cover and find the preset switch S1 and S2 on the MAIN CPU board.
3. Set the preset switch so that the lightest part of the pattern is "lightly" printed as the sample below.
The intensity can be fine tuned in 32 steps by the combination of the segments #1 to #5 of S2.
4. Refasten the top cover.

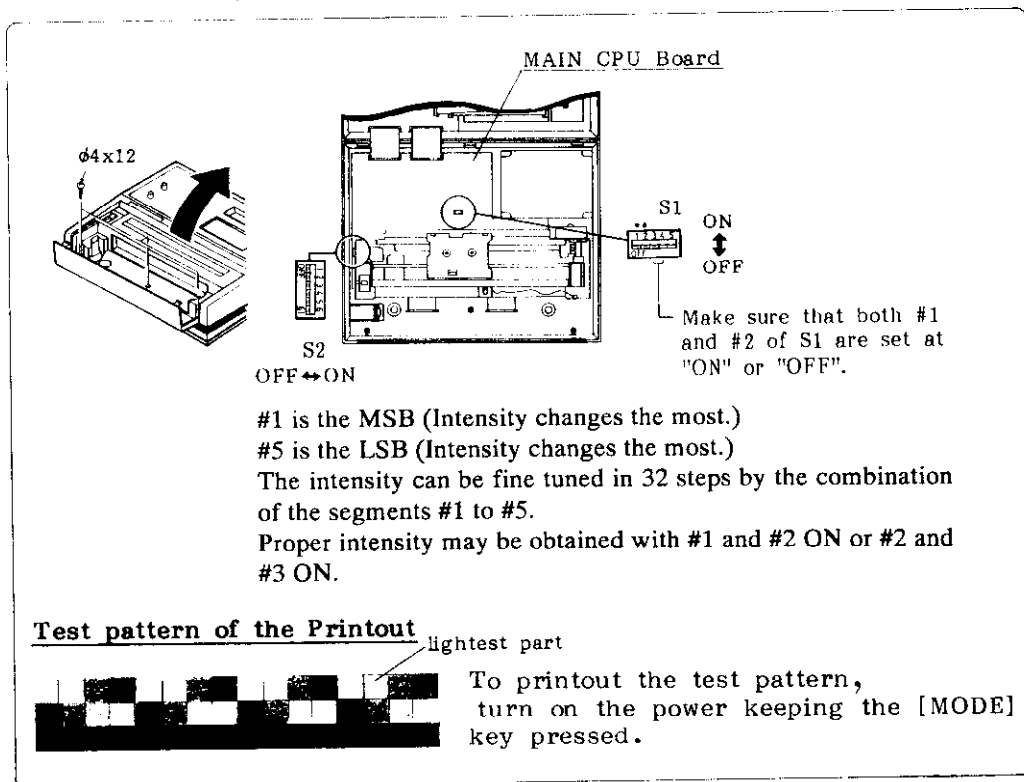

Picture V-H ratio

The vertical-horizontal ratio of facsimile picture recording can be changed in two steps; V:H=1:1 or V:H=1.25:1. For natural and easy reading of the recordings, a V-H ratio 1.25:1 is adopted as the standard setting at delivery. As necessary, change the setting of the setting of the preset switch as described below.

Note that the text printout is not affected by this setting.

1. Perform steps 1 and 2 of "Print intensity" to fine the slide switch array S1.
2. Set the right most switch (#5) to ON (V:H=1:1) or OFF (V:H=1.25:1).
3. Refasten the top cover.

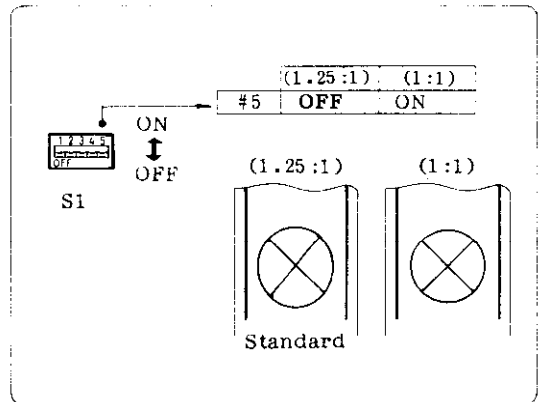

Beep Volume

A built-in loudspeaker is employed to provide notification of an incoming signal and also to emit a beep sound when a key is operated or an alarm condition is detected.

On operator's demand, the beep sound level, with respect to the signal sound level, can be adjusted internally. (The beep volume is set to the maximum level at delivery.)

1. Lift up the top cover of the recorder, referring to the illustration on the preceding page.
2. Find the preset pot. R38 on the LED board. See the figure at the right.
3. Turn the pot. for until the desired beep sound level is obtained.
4. Refasten the top cover.

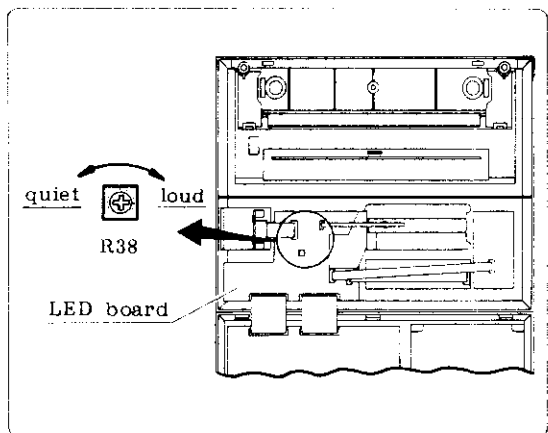

FACSIMILE STATION MAP

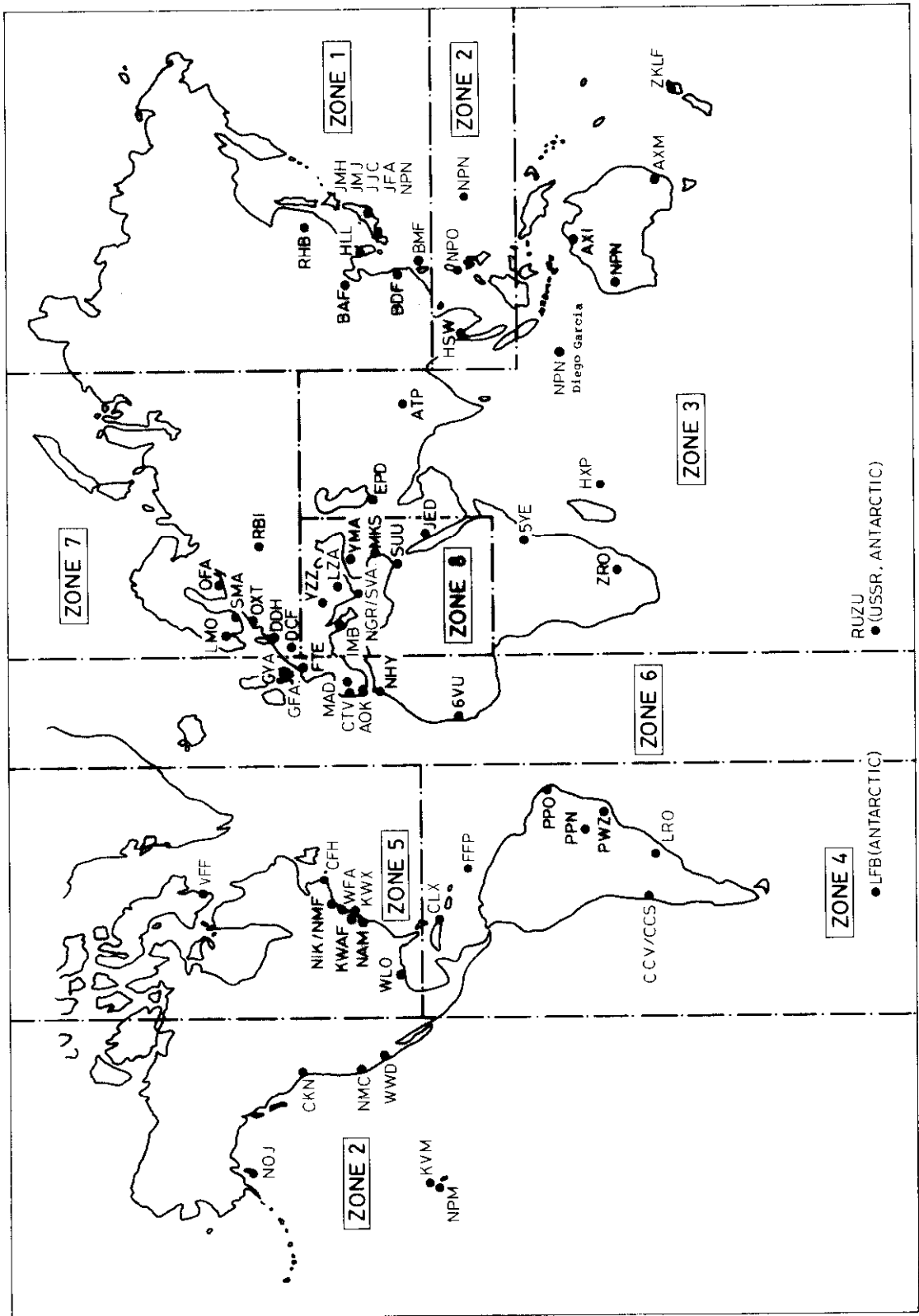

ZONE 1 NORTH PACIFIC OCEAN WESTERN PART		
STA- TION	CALL SIGN	TRANSMITTED FROM
0	JMH	Tokyo JAPAN
1	JMJ	Tokyo JAPAN
2	JJC	Tokyo JAPAN
3	9VF *	Tokyo Via SINGAPORE
4	3SD	Beijing CHINA
5	BAF	Beijing CHINA
6	BDF	Shanghai CHINA
7	BMF	Taipei TAIWAN
8	RHB	Khabarovsk RUSSIA
9	HLL	Seoul KOREA

ZONE 2 NORTH PACIFIC OCEAN EASTERN PART		
STA- TION	CALL SIGN	TRANSMITTED FROM
0	NPN	Guam MARIANA IS.
1	NPO	Sanglay Point PHILIPPINES
2	HSW	Bangkok THAILAND
3	NPM	Pearl Harbour USA
4	KVM	Honolulu USA
5	NOJ	Kodiak Alaska USA
6	KXN	Esquimalt CANADA
7	NMC	San Francisco USA
8	WWD	La Jolla USA
9	AUX	

ZONE 3 SOUTH PACIFIC OCEAN, INDIAN OCEAN, PERSIAN GULF		
STA- TION	CALL SIGN	TRANSMITTED FROM
0	AXI	Darwin AUSTRALIA
1	AXM	Camberra AUSTRALIA
2	ZKLF	Auckland NWE ZEALAND
3	NPN	Guam Via AUSTRALIA
4	ATP	New Delhi INDIA
5	EPD *	Teheran IRAN
6	5YE	Nairobi Via Diego Garcia KENYA
7	ZRO	Pretoria SOUTH AFRICA
8	HXP	Saint Denis MAURITIUS
9	RUZU	Molodzhnava RUSSIA

ZONE 4 SOUTH ATLANTIC OCEAN		
STA- TION	CALL SIGN	TRANSMITTED FROM
0	CLX	Casablanca CUBA
1	FFP	Fort de France MARTINIQUE
2	GVA	
3	PPN	Brasilia BRASIL
4	PWZ	Rio de Janeiro BRASIL
5	PRO *	Orinda BRASIL
6	LRO	Buenos Aires ARGENTINE
7	CCS	Santiago CHILE
8	LFB	Centro Meteorologico ANTARCTIC
9	CBV	Valparaiso Armada de CHILE

ZONE 5 NORTH ATLANTIC OCEAN WESTERN PART		
STA- TION	CALL SIGN	TRANSMITTED FROM
0	WLO	Mobile USA
1	NAM	Norfolk USA
2	KWAF	Washington DC USA
3	KW	Lewes USA
4	WFH	Dalaware USA
5	NIK	Brentwood USA
6	NMF	Boston USA
7	CFH	Halifax CANADA
8	VFF	Frobisher CANADA
9	OPT	Skamlebaek GREENLAND
	XPM	

ZONE 6 NORTH ATLANTIC OCEAN EASTERN PART		
STA- TION	CALL SIGN	TRANSMITTED FROM
0	GFA	Bracknell UK
1		Bracknell UK
2	GZZ *	Northwood UK
	GJI *	
3	FTE	Paris FRANCE
4	CTV	Monsanto PORTUGAL
5	AOK	Rota SPAIN
6	MAD	Madrid SPAIN
7	NPN *	
8	NHY	Kenitra MOROCCO
9	6VU	Dakar SENEGAL
	AUX	

ZONE 7 NORTH ATLANTIC OCEAN NORTHERN PART		
STA- TION	CALL SIGN	TRANSMITTED FROM
0	DCF	Offenbach GERMANY
1	DDK	Hamburg GERMANY
2	DDH *	
3	OXT	Copenhagen DENMARK
4	OLT	Praha-Moudrany CZECHOSLOVAKIA
5	SMA	Norrkoping SWEDEN
6	LMO	Oslo NORWAY
7	OFH *	Helsinki FINLAND
	OHG *	
8	OPW	Vaasa FINLAND
9	TFA *	Reykjavic ICELAND
	RBI	Moscow USSR
	AUX	

ZONE 8 MEDITERRANEAN SEA		
STA- TION	CALL SIGN	TRANSMITTED FROM
0	IMB	Rome ITALY
1	NPN	Athens GREECE
2	5VG4 *	
3	YZZ	Beograd YUGOSLAVIA
4	NGR	Athens GREECE
5	LZJ2	Sofia BULGARIA
6	YMA	Ankara TURKEY
7	MKS	Episkopi CYPRUS
8	SUJ	Cairo EGYPT
9	JED	Jeddah SAUDI ARABIA
	HZN *	
	AUX	

FACSIMILE STATION LIST

ZONE[0] is allocated for private channels.
(10 channels each for 12 stations)
*: Callsign not displayed.

FACSIMILE STATION LIST (ALPHABETICAL ORDER)

	Nation	City	Zone No.	Station No.	Call sign	Remarks	T	Nation	City	Zone No.	Station No.	Call sign	Remarks
A	ANTARCTIC	Meteorologic.	4	8	LFB		M	MARIANA IS.	Guam	2	0	NPN	US Navy
	ARGENTINE	Buenos Aires	4	5	LRO			MARTINIQUE	Fort de France	4	1	FFP	
	AUSTRALIA	Canberra	3	1	AXM			MAURITIUS	Sain Denis	3	8	HXP	
		Darwin	3	0	AXI			MOROCCO	Kenitara	6	7	NHY	
		H.E.Holt	3	3	NPN	US Navy							
B	BRAZIL	Brasilia	4	3	PPN		X	NEW ZEALAND	Auckland	3	2	ZKLF	
		Orinda	4	4	PPO			NORWAY	Oslo	7	5	LMO	
		Rio de Janeiro	4	4	PWZ		P	PHILIPPINES	Sangley Point	2	1	NPO	US Navy
	BULGARIA	Sofia	8	4	LZ32			PORTUGAL	Monsanto	6	4	CTV	
C	CANADA	Esquimalt	2	6	CKN		S	SENEGAL	Dakar	6	8	6VU	
		Frobisher	5	8	VFF			SAUDI ARABIA	Jeddah	8	8	JED	
		Halifax	5	7	CFH								
	CHILE	Belloto	4	7	CCV			SOUTH AFRICA	Pretoria	3	7	ZRO	
		Santiago	4	6	CCS			SPAIN	Rota	6	5	AOK	US Navy
		Valparaiso	4	9	CBV				Madrid	6	6	MAD	
	CHINA	Beijing	1	4	3SD			SWEDEN	Norrkoping	7	4	SMA	
		Beijing	1	5	BAF								
		Shanghai	1	6	BDF		T	TAIWAN	Taipei	1	7	BMF	
	CUBA	Casablenea	4	0	CLX			THAILAND	Bangkok	2	2	HSW	
	CYPRUS	Epsikopti	8	6	MKS			TURKEY	Ankara	8	5	YMA	
	CZECHOSLOVAKIA	Praha-Modrany	7	3	OLT								
D	DENMARK	Copenhagen	7	2	OXT		U	UK	Bracknell	6	0	GFA	
E	EGYPT	Cairo	8	7	SUU				Bracknell	6	1	GFA	
F	FINLAND	Helsinki	7	6	OFA				Northwood	4	2	GYA	For S.A.
					OFH				Northwood	6	2	GYA	
					OHG							GZZ	
	FRANCE	Vaasa	7	7	OFW			USA	Roston	5	5	NIK	
		Paris	6	3	FTE				Boston	5	6	NMF	
									Bretwood	5	4	WFH	
	GREECE	Athens	8	1	NPN				Diego Garcia	3	5	NPN	
					SVG4				Honolulu	2	4	KVM	
	GREENLAND	Skamtebaek	5	9	XPM	US Navy			Kodiak Alaska	2	5	NOJ	
					NGR				La Jolla	2	8	WWD	
					OXT				Lewes	5	3	KWX	
									Delaware	5	3	KWX	
									Mobile	5	0	WLO	
									Norfolk	5	1	NAM	
I	ICELAND	Reykjavik	7	7	TFA				Pearl Harbour	2	3	NPM	US Navy
	INDIA	New Delhi	3	4	ATP				San Francisco	2	2	NMC	
	IRAN	Teheran	3	5	EPD				Washington DC	5	2	KWAF	AIR Force
	ITALY	Rome	8	0	IME			RUSSIA	Khabarovsk	1	8	RUB	
									Molodezhnaya	3	9	RUZU	
J	JAPAN	Tokyo	1	0	JMH	No.1			Moscow	7	8	RBI	
		Tokyo	1	1	JMJ	No.2			Hamburg	7	1	DDK	
		Tokyo	1	2	JJC	JMSA & Kyodo	W	GERMANY	Offenbach	7	0	DDH	
					9VF				Belgrade	8	2	DCZ	
		Tokyo	1	3	JFA	Chuo Gyogyo						YZZ	
K	KENYA	Nairobi	3	6	5VE		Y	YUGOSLAVIA					
	KOREA	Seoul	1	9	HLL								

PRIVATE CHANNEL LIST

Zone	Station	Channel	Call sign	Remarks
0	0	0	PRV	
		1		
		2		
		3		
		4		
		5		
		6		
		7		
		8		
		9		
	9		AUX	

NAVTEX STATION LIST

Nav-area	Stn ID	Country	City	Time Schedule (UTC)	Remarks	
I	B	NORWAY	Bodo	0018, 0418, 0900, 1218, 1618, 2100	Pre-operational	
	C	RUSSIA	Murmansk	0120, 0520, 0920, 1320, 1720, 2120		
	F	RUSSIA	Arkhangelsk	0200, 0600, 1000, 1400, 1800, 2200		
	G	U.K.	Cullercoats	0048, 0448, 0848, 1248, 1648, 2048		
	H	SWEDEN	Haernoessand	0000, 0400, 0800, 1200, 1600, 2000		
	J	SWEDEN	Stockholm	0300, 0730, 1130, 1530, 1930, 2330		
	L	NORWAY	Rogaland	0148, 0548, 0948, 1348, 1748, 2148		
	O	U.K.	Portpatrick	0130, 0530, 0930, 1330, 1730, 2130		
	P	NETH. L	Scheveningen	0348, 0748, 1148, 1548, 1948, 2348		
	R	ICELAND	Reykjavik	0318, 0718, 1118, 1518, 1918, 2318		
	S	U.K.	Niton	0018, 0418, 0900, 1218, 1618, 2100		
	T	BELGIUM	Oostende	0248, 0648, 1048, 1448, 1848, 2248		
U	RUSSIA	Tallin	0030, 0430, 0830, 1230, 1630, 2030			
V	NORWAY	Vardoe	0300, 0700, 1100, 1500, 1900, 2300			
II	A	FRANCE	Brest-Le conq	0030, 0430, 0830, 1230, 1630, 2030	Planned	
	D	SPAIN	Finisterre			
	F	PORTUGAL	Azores		0050, 0450, 0850, 1250, 1650, 2050	Planned
	I	SPAIN	Canary Islands		0100, 0500, 0900, 1300, 1700, 2100	
	R	PORTUGAL CAMEROON	Lisbon Douala		0250, 0650, 1050, 1450, 1850, 2250	
III	A	RUSSIA	Novorossiysk	0300, 0700, 1100, 1500, 1900, 2300	Planned	
	B	RUSSIA	Mariupol	0100, 0500, 0900, 1300, 1700, 2100		
	C	RUSSIA	Odessa	0230, 0630, 1030, 1430, 1830, 2230		
	D	TURKEY	Istanbul	0030, 0430, 0830, 1230, 1630, 2030		
	E	TURKEY	Samsun	0040, 0440, 0840, 1240, 1640, 2040		
	F	TURKEY	Antalya	0050, 0450, 0850, 1250, 1650, 2050		
	G	SPAIN	Tarifa	0100, 0500, 0900, 1300, 1700, 2100	Planned	
	H	GREECE	Iraklion	0110, 0510, 0910, 1310, 1710, 2110		
	I	TURKEY	Izmir	0120, 0520, 0920, 1320, 1720, 2120		
	J	BULGARIA	Varna	0130, 0530, 0930, 1330, 1730, 2130		
	K	GREECE	Kerkyra	0140, 0540, 0940, 1340, 1740, 2140		
	L	GREECE	Limnos	0150, 0550, 0950, 1350, 1750, 2150		
	M	CYPRUS	Troodos	0200, 0600, 1000, 1400, 1800, 2200	Planned Planned	
	N	EGYPT	Alexandria	0210, 0610, 1010, 1410, 1810, 2210		
	O	MALTA	Malta	0220, 0620, 1020, 1420, 1820, 2220		
	P	ISRAEL	Haifa	0020, 0420, 0820, 1220, 1620, 2020		
Q	YUGO.	Split	0250, 0650, 1050, 1450, 1850, 2250			
Z	SPAIN FRANCE	Cabo La Nao La Garde				
IV	A	USA	Miami	0000, 0600, 1200, 1800	Pre-operational	
	B	BERMUDA	St. Georges	0100, 0700, 1300, 1900		
	F	USA	Boston	0445, 1045, 1645, 2245		
	G	USA	New Orleans	0300, 0900, 1500, 2100	Under trials Pre-operational Pre-operational	
	K	CANADA	Sydney	0040, 0540, 0940, 1340, 1740, 2140		
	N	USA	Portsmouth	0130, 0730, 1330, 1930		
R	USA	San Juan	0415, 1015, 1615, 2215			

Nav-area	Stn ID	Country	City	Time Schedule (UTC)	Remarks
V		URUGUAY	Colonia		Planned
		URUGUAY	Laguna D Sauce		Planned
		URUGUAY	La Paloma		Planned
		URUGUAY	Montevideo		Planned
		URUGUAY	Punta de Este Salto		Planned
VI	A	ARGENTINA	Ushuaia	0240, 0840, 1440, 2040	planned
	B	ARGENTINA	Rio Gallegos	0140, 0740, 1340, 1940	
	C	ARGENTINA	Rivadavia	0040, 0640, 1240, 1840	
	D	ARGENTINA	Bahia Blanca	0210, 0810, 1410, 2010	
	E	ARGENTINA	Mar Del Plata	0110, 0710, 1310, 1910	
	F	ARGENTINA	Buenos Aires	0510, 1110, 1710, 2310	
	G	ARGENTINA	Rosario	0110, 0610, 1210, 1810	
VII	C	S. AFRICA	CAPETOWN	0020, 0420, 0820, 1220, 1620, 2020	
	D	S. AFRICA	DURBAN	0120, 0520, 0920, 1320, 1720, 2120	
VIII	G	INDIA	Bombay	0100, 0500, 0900, 1300, 1700, 2100	
	P	INDIA	Madras	0230, 0630, 1030, 1430, 1830, 2230	
IX	H	S. ARABIA	Jeddah	0010, 0410, 0810, 1210, 1610, 2010	Planned
	G	S. ARABIA	Dammam		Planned
	X	EGYPT	Ismailia		Planned
	B	BAHRAIN	Hamata		Planned
XI	V	USA	Guam	0100, 0700, 1300, 1900	
	C	SINGAPORE	Jurong	0020, 0420, 0820, 1220, 1620, 2020	
	G	JAPAN	Naha	0100, 0500, 0900, 1300, 1700, 2100	
	H	JAPAN	Moji	0110, 0510, 0910, 1310, 1710, 2110	
	I	JAPAN	Yokohama	0120, 0520, 0920, 1320, 1720, 2120	
	J	JAPAN	Otaru	0130, 0530, 0930, 1330, 1730, 2130	
	K	JAPAN	Kushiro	0140, 0540, 0940, 1340, 1740, 2140	
	L	HONG KONG	Hong Kong	0200, 0600, 1000, 1400, 1800, 2200	
	M	CHINA	Zhanjiang	0210, 0610, 1010, 1410, 2210	
	N	CHINA	Guangzhou		
	O	CHINA	Fuzhou	0250, 0650, 1050, 1450, 2250	
	R	CHINA	Dalian		
	Q	CHINA	Shanghai		
S	CHINA	Tianjin	0240, 0640, 1040, 1440, 2240		
		CHINA	Hainan		
XII	C	USA	San Francisco	0400, 1000, 1600, 2200	Pre-operational
	W	USA	Astoria	0130, 0730, 1330, 1930	Pre-operational
	Q	USA	Cambria	0445, 1045, 1645, 2245	Pre-operational
	J	USA	Kodiak	0300, 0900, 1500, 2100	Pre-operational
	O	USA	Honolulu	0040, 0640, 1240, 1840	Planned
	X	USA	Adak	0000, 0600, 1200, 1745	
XIII	A	RUSSIA	Vladivostok	0000, 0400, 0800, 1200, 1600, 2000	
	B	RUSSIA	Kholmsk	0010, 0410, 0810, 1210, 1610, 2010	
	C	RUSSIA	Petropavlovsk	0050, 0450, 0850	
	D	RUSSIA	Magadan	0030, 0430, 0830, 1230, 1630, 2030	
	E	RUSSIA	Beringovskiy	0040, 0440, 0840, 1240, 1640, 2040	
	F	RUSSIA	Providenya	0050, 0450, 0850, 1250, 1650, 2050	

Nav-area	Stn ID	Country	City	Time Schedule (UTC)	Remarks
XV	A	CHILE	Antofagasta	0010, 0410, 0810, 1210, 1610, 2010	
	B	CHILE	Valparaiso		
	C	CHILE	Talcahuano		
	D	CHILE	Puerto Montt		
	E	CHILE	Magallanes		
XVI	S	PERU	Paíta	0300, 0700, 1100, 1500, 1900, 2300	Planned
	U	PERU	Callao	0320, 0720, 1120, 1520, 1920, 2320	Planned
	W	PERU	Mollendo	0340, 0740, 1140, 1540, 1940, 2340	Planned

NOTE: The list above shows the stations registered with the International Frequency Registration Board (IFRB) for transmission of 518 kHz (as of Jan. 1994). Note that not all stations are operational.

APPENDIX D. IMPROVEMENT OF RECEIVER S/N RATIO (Remedy for RFI)

PROBLEM

FAX-208A/N and FAX-214 may experience a decrease in receiver sensitivity. This may occur if the coaxial cable connected between the optional preamp unit and the main unit is extended by the use of an extension cable.

CAUSE

The outer conductor of the coaxial cable picks up unwanted signal/noise.

OUTLINE OF FIELD MODIFICATION

Connect a vinyl ground wire between the shield of the coaxial cable at the base of the preamp unit and the mast. Figures 1 and 2 on the next page illustrate how to do this modification.

NOTE: The coaxial cable should not be laid close to or bound with power cables or control cables.

MODIFICATION REQUIRED/NOT REQUIRED

Required

- 1) If most of the original supply coaxial cable is outside of the mast.
- 2) Extension cable is used.
- 3) Where RFI/noise is a problem.

Not Required

- 1) Coaxial cable runs inside a steel mast or conduit.
- 2) Where the original supply coaxial cable has been replaced (or can be replaced) with one having an armor.
- 3) For FRP ships and non-metallic masts where a good ground cannot be made at the base of the preamp unit.
- 4) If the coaxial cable can be shortened.

FACTORY-MODIFIED SETS

If the factory-added ground wire is not long enough, run an additional ground wire between the ground terminal and the mast. See the figure below.

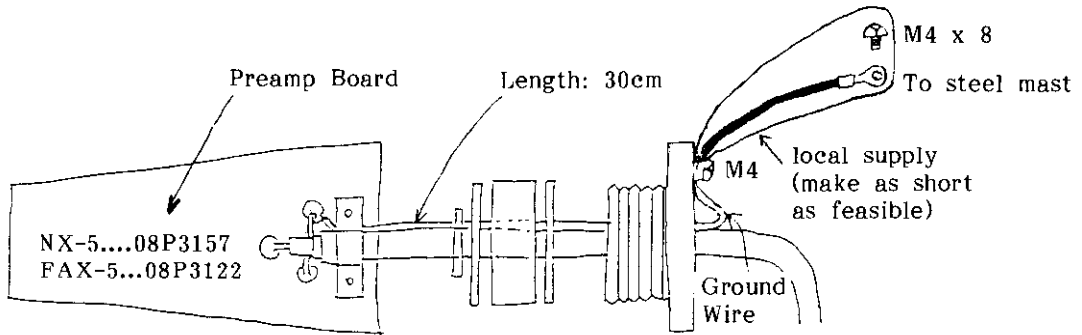

Fig. 1

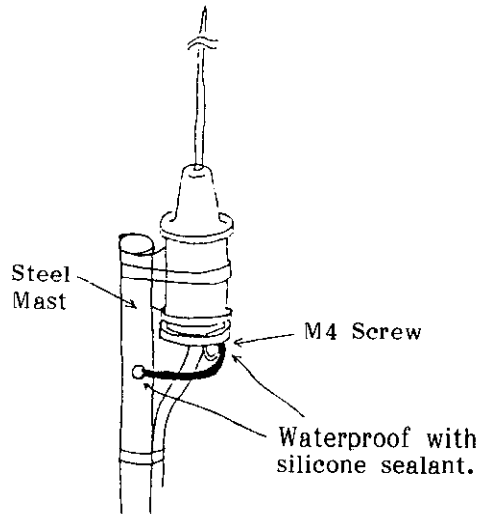
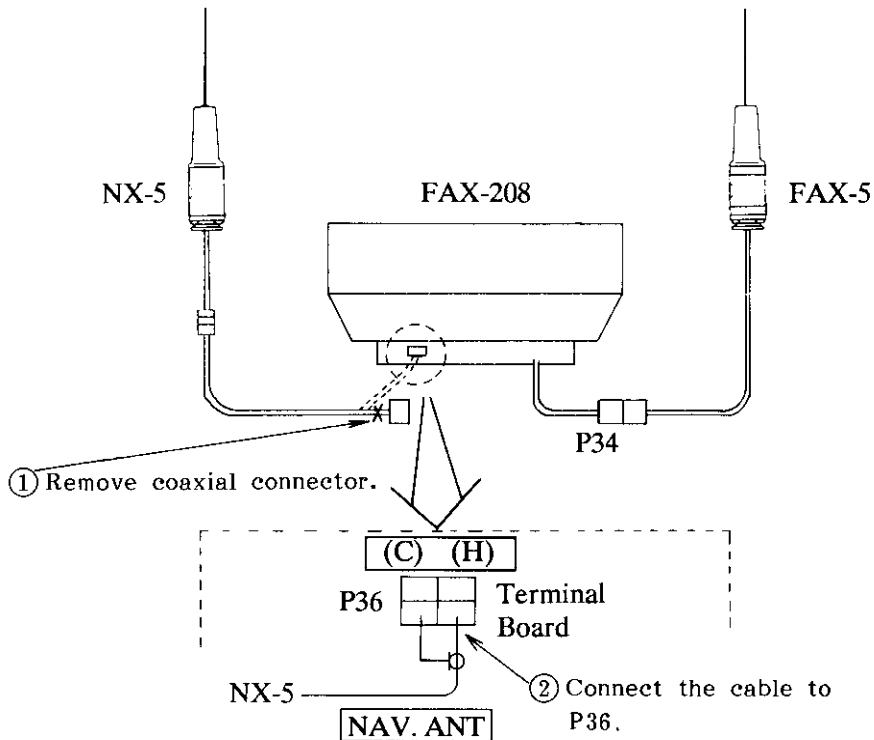

Fig. 2

APPENDIX E. IMPROVEMENT OF NAVTEX RECEIVING SIGNAL SENSITIVITY

If navtex receiving signal sensitivity is very poor, mount an additional antenna with the preamp unit (NX-5) for exclusive reception of navtex signal.



Referring to Appendix D, modify the preamp unit (NX-5) to improve receiving sensitivity. Set preset switch S2 on the TB board (behind the rear panel) to ON.

Switch	Position	Remarks
S1	WIRE	Factory setting (No use of FAX-5)
	ACTIVE	9Vdc is supplied to FAX-5.
S2	OFF	Factory setting (No use of NX-5)
	ON	9Vdc is supplied to NX-5.

